



GE Fanuc Automation

Computer Numerical Control Products

Alpha Series Servo Amplifier Unit

Descriptions Manual

B- 65192EN/02

March 1998

Warnings and notices for this publication

GFLE-003

Warning

In this manual we have tried as much as possible to describe all the various matters. However, we cannot describe all the matters which must not be done, or which cannot be done, because there are so many possibilities.

Therefore, matters which are not especially described as possible in this manual should be regarded as “impossible”.

Notice

This document is based on information available at the time of its publication. While efforts have been made to be accurate, the information contained herein does not purport to cover all details or variations in hardware or software, nor to provide every contingency in connection with installation, operation, or maintenance. Features may be described herein which are not present in all hardware and software systems. GE Fanuc Automation assumes no obligation of notice to holders of this document with respect to changes subsequently made.

GE Fanuc Automation makes no representation or warranty, expressed, implied, or statutory with respect to, and assumes no responsibility for accuracy, completeness, sufficiency, or usefulness of the information contained herein. No warranties of merchantability or fitness for purpose shall apply.

The following are Registered Trademarks of GE Fanuc Automation

CIMPLICITY® Genius®

The following are Trademarks of GE Fanuc Automation

Alarm Master	PROMACRO
CIMSTAR	Series Five
Field Control	Series 90
Genet	Series One
Helpmate	Series Six
LogicMaster	Series Three
Modelmaster	VuMaster
PowerMotion	Workmaster
ProLoop	

**© Copyright 1998 FANUC Ltd.
Authorized Reproduction GE Fanuc Automation Europe S.A.**

All Rights Reserved

No part of this manual may be reproduced in any form.
All specifications and designs are subject to change without notice.

Note

GE Fanuc has modified this manual created by FANUC:

1. We have added a supplementary Descriptions Manual for the SVUC Amplifier.
2. We have also added a supplementary Descriptions Manual for the SVU3 Amplifier.
3. In addition, we have added supplementary power cable and jumper information on page 47a. This information will more clearly explain the diagram on the preceding page (page 47).

We believe our customers will find it more helpful to have all this information printed and bound within one manual for the SVU Amplifier.

SAFETY PRECAUTIONS

This "Safety Precautions" section describes the precautions which must be observed to ensure safety when using FANUC control motor amplifiers. Users of any control motor amplifier model are requested to read the "Safety Precautions" carefully before first using the amplifier. Users should also read the relevant description in this manual to become fully familiar with the functions of the control motor amplifier.

Contents

1. DEFINITION OF WARNING, CAUTION, AND NOTE	s-2
2. WARNINGS AND CAUTIONS RELATING TO MOUNTING	s-3
3. WARNINGS AND CAUTIONS RELATING TO A PILOT RUN	s-7
4. WARNINGS AND CAUTIONS RELATING TO MAINTENANCE	s-9

1

DEFINITION OF WARNING, CAUTION, AND NOTE

This manual includes safety precautions for protecting the user and preventing damage to the machine. Precautions are classified into Warning and Caution according to their bearing on safety. Also, supplementary information is described as a Note. Read the Warning, Caution, and Note thoroughly before attempting to use the machine.

WARNING

Applied when there is a danger of the user being injured or when there is a damage of both the user being injured and the equipment being damaged if the approved procedure is not observed.

CAUTION

Applied when there is a danger of the equipment being damaged, if the approved procedure is not observed.

NOTE

The Note is used to indicate supplementary information other than Warning and Caution.

- **Read this manual carefully, and store it in a safe place.**

2 WARNINGS AND CAUTIONS RELATING TO MOUNTING

WARNING

Check the specification code of the amplifier.

Check that the delivered amplifier is as originally ordered.

Mount a ground fault interrupter.

To guard against fire and electric shock, fit the factory power supply or machine with a ground fault interrupter (designed for use with an inverter).

Securely ground the amplifier.

Securely connect the ground terminal and metal frame of the amplifier and motor to a common ground plate of the power magnetics cabinet.

Be aware of the weight of the amplifier and other components.

Control motor amplifiers and AC reactors are heavy. When transporting them or mounting them in the cabinet, therefore, be careful not to injure yourself or damage the equipment. Be particularly careful not to jam your fingers between the cabinet and amplifier.

Never ground or short-circuit either the power supply lines or power lines.

Protect the lines from any stress such as bending. Handle the ends appropriately.

Ensure that the power supply lines, power lines, and signal lines are securely connected.

A loose screw, loose connection, or the like will cause a motor malfunction or overheating, or a ground fault.

Insulate all exposed parts that are charged.

Never touch the regenerative discharge resistor or radiator directly.

The surface of the radiator and regenerative discharge unit become extremely hot. Never touch them directly. An appropriate structure should also be considered.

Close the amplifier cover after completing the wiring.

Leaving the cover open presents a danger of electric shock.

CAUTION**Do not step or sit on the amplifier.**

Also, do not stack unpacked amplifiers on top of each other.

Use the amplifier in an appropriate environment.

See the allowable ambient temperatures and other requirements, given in the corresponding descriptions.

Protect the amplifier from corrosive or conductive mist or drops of water.

Use a filter if necessary.

Protect the amplifier from impact.

Do not place anything on the amplifier.

Do not disassemble the amplifier.**Do not block the air inlet to the radiator.**

A deposit of coolant, oil mist, or chips on the air inlet will result in a reduction in the cooling efficiency. In some cases, the required efficiency cannot be achieved. The deposit may also lead to a reduction in the useful life of the semiconductors. Especially, when outside air is drawn in, mount filters on both the air inlet and outlet. These filters must be replaced regularly. So, an easy-to-replace type of filter should be used.

Connect the power supply lines and power lines to the appropriate terminals.**Connect the signal lines to the appropriate connectors.****Ensure that the cables used for the power supply lines and power lines are of the appropriate diameter and temperature ratings.****Do not apply an excessively large force to plastic parts.**

If a plastic section breaks, it may cause internal damage, thus interfering with normal operation. The edge of a broken section is likely to be sharp and, therefore, presents a risk of injury.

Before connecting the power supply wiring, check the supply voltage.

Check that the supply voltage is within the range specified in this manual, then connect the power supply lines.

CAUTION

Ensure that the combination of motor and amplifier is appropriate.

Ensure that valid parameters are specified.

Specifying an invalid parameter for the combination of motor and amplifier may not only prevent normal operation of the motor but also result in damage to the amplifier.

Ensure that the amplifier and peripheral equipment are securely connected.

Check that the magnetic contactor, circuit breaker, and other devices mounted outside the amplifier are securely connected to each other and that those devices are securely connected to the amplifier.

Check that the amplifier is securely mounted in the power magnetics cabinet.

If any clearance is left between the power magnetics cabinet and the surface on which the amplifier is mounted, dust entering the gap may build up and prevent the normal operation of the amplifier.

Apply appropriate countermeasures against noise.

Adequate countermeasures against noise are required to maintain normal operation of the amplifier. For example, signal lines must be routed away from power supply lines and power lines.

NOTE

Keep the nameplate clearly visible.

Keep the legend on the nameplate clearly visible.

After unpacking the amplifier, carefully check for any damage.

Mount the amplifier in a location where it can be easily accessed to allow periodic inspection and daily maintenance.

Leave sufficient space around the machine to enable maintenance to be performed easily.

Do not place any heavy objects such that they would interfere with the opening of the doors.

Keep the parameter table and spare parts at hand.

Also, keep the specifications at hand. These items must be stored in a location where they can be retrieved immediately.

Provide adequate shielding.

A cable to be shielded must be securely connected to the ground plate, using a cable clamp or the like.

3

WARNINGS AND CAUTIONS RELATING TO A PILOT RUN

WARNING

Before turning on the power, check that the cables connected to the power magnetics cabinet and amplifier, as well as the power lines and power supply lines, are securely connected. Also, check that no lines are slack.

Before turning on the power, ensure that the power magnetics cabinet is securely grounded.

Before turning on the power, check that the door of the power magnetics cabinet and all other doors are closed.

Ensure that the door of the power magnetics cabinet containing the amplifier, and all other doors, are securely closed. During operation, all doors must be closed and locked.

Apply extreme caution if the door of the power magnetics cabinet or another door must be opened.

Only a person trained in the maintenance of the corresponding machine or equipment should open the door, and only after shutting off the power supply to the power magnetics cabinet (by opening both the input circuit breaker of the power magnetics cabinet and the factory switch used to supply power to the cabinet). If the machine must be operated with the door open to enable adjustment or for some other purpose, the operator must keep his or her hands and tools well away from any dangerous voltages. Such work must be done only by a person trained in the maintenance of the machine or equipment.

When operating the machine for the first time, check that the machine operates as instructed.

To check whether the machine operates as instructed, first specify a small value for the motor, then increase the value gradually. If the motor operates abnormally, perform an emergency stop immediately.

After turning on the power, check the operation of the emergency stop circuit.

Press the emergency stop button to check that the motor stops immediately, and that the power being supplied to the amplifier is shut off by the magnetic contactor.

Before opening a door or protective cover of a machine to enable adjustment of the machine, first place the machine in the emergency stop state and check that the motor has stopped.

CAUTION**Note whether an alarm status relative to the amplifier is displayed at power-up or during operation.**

If an alarm is displayed, take appropriate action as explained in the maintenance manual. If the work to be done requires that the door of the power magnetics cabinet be left open, the work must be carried out by a person trained in the maintenance of the machine or equipment. Note that if some alarms are forcibly reset to enable operation to continue, the amplifier may be damaged. Take appropriate action according to the contents of the alarm.

Before operating the motor for the first time, mount and adjust the position and speed detectors.

Following the instructions given in the maintenance manual, adjust the position and speed detectors for the spindle so that an appropriate waveform is obtained. If the detectors are not properly adjusted, the motor may not rotate normally or the spindle may fail to stop as desired.

If the motor makes any abnormal noise or vibration while operating, stop it immediately.

Note that if operation is continued in spite of there being some abnormal noise or vibration, the amplifier may be damaged. Take appropriate corrective action, then resume operation.

Observe the ambient temperature and output rating requirements.

The continuous output rating or continuous operation period of some amplifiers may fall as the ambient temperature increases. If the amplifier is used continuously with an excessive load applied, the amplifier may be damaged.

4

WARNINGS AND CAUTIONS RELATING TO MAINTENANCE

WARNING

Read the maintenance manual carefully and ensure that you are totally familiar with its contents.

The maintenance manual describes daily maintenance and the procedures to be followed in the event of an alarm being issued. The operator must be familiar with these descriptions.

Notes on replacing a fuse or PC board

- 1) Before starting the replacement work, ensure that the circuit breaker protecting the power magnetics cabinet is open.
- 2) Check that the red LED that indicates that charging is in progress is not lit. The position of the charging LED on each model of amplifier is given in this manual. While the LED is lit, hazardous voltages are present inside the unit, and thus there is a danger of electric shock.
- 3) Some PC board components become extremely hot. Be careful not to touch these components.
- 4) Ensure that a fuse having an appropriate rating is used.
- 5) Check the specification code of a PC board to be replaced. If a modification drawing number is indicated, contact FANUC before replacing the PC board. Also, before and after replacing a PC board, check its pin settings.
- 6) After replacing the fuse, ensure that the screws are firmly tightened. For a socket-type fuse, ensure that the fuse is inserted correctly.
- 7) After replacing the PC board, ensure that it is securely connected.
- 8) Ensure that all power lines, power supply lines, and connectors are securely connected.

Take care not to lose any screws.

When removing the case or PC board, take care not to lose any screws. If a screw is lost inside the unit and the power is turned on, the machine may be damaged.

Notes on replacing the battery of the absolute pulse coder

Replace the battery only while the power is on. If the battery is replaced while the power is turned off, the stored absolute positioning data will be lost. Some series servo amplifier modules have batteries in their servo amplifiers. To replace the battery of any of those models, observe the following procedure: Open the door of the power magnetics cabinet; Leave the control power of the power supply module on; Place the machine in the emergency stop state so that the power being input to the amplifier is shut off; Then, replace the battery. Replacement work should be done only by a person who is trained in the related maintenance and safety requirements. The power magnetics cabinet in which the servo amplifier is mounted has a high-voltage section. This section presents a severe risk of electric shock.

WARNING**Check the number of any alarm.**

If the machine stops upon an alarm being issued, check the alarm number. Some alarms indicate that a component must be replaced. If the power is reconnected without first replacing the failed component, another component may be damaged, making it difficult to locate the original cause of the alarm.

Before resetting an alarm, ensure that the original cause of the alarm has been removed.

Contact FANUC whenever a question relating to maintenance arises.

CAUTION**Ensure that all required components are mounted.**

When replacing a component or PC board, check that all components, including the snubber capacitor, are correctly mounted. If the snubber capacitor is not mounted, for example, the IPM will be damaged.

Tighten all screws firmly.**Check the specification code of the fuse, PC board, and other components.**

When replacing a fuse or PC board, first check the specification code of the fuse or PC board, then mount it in the correct position. The machine will not operate normally if a fuse or PC board having other than the correct specification code is mounted, or if a fuse or PC board is mounted in the wrong position.

Mount the correct cover.

The cover on the front of the amplifier carries a label indicating a specification code. When mounting a previously removed front cover, take care to mount it on the unit from which it was removed.

Notes on cleaning the heat sink and fan

- 1) A dirty heat sink or fan results in reduced semiconductor cooling efficiency, which degrades reliability. Periodic cleaning is necessary.
- 2) Using compressed air for cleaning scatters the dust. A deposit of conductive dust on the amplifier or peripheral equipment will result in a failure.
- 3) To clean the heat sink, do so only after turning the power off and ensuring that the heat sink has cooled to room temperature. The heat sink becomes extremely hot, such that touching it during operation or immediately after power-off is likely to cause a burn. Be extremely careful when touching the heat sink.

Notes on removing the amplifier

Before removing the amplifier, first ensure that the power is shut off. Be careful not to jam your fingers between the power magnetics cabinet and amplifier.

NOTE

Ensure that the battery connector is correctly inserted.

If the power is shut off while the battery connector is not connected correctly, the absolute position data for the machine will be lost.

Store the manuals in a safe place.

The manuals should be stored in a location where they can be accessed immediately if so required during maintenance work.

Notes on contacting FANUC

Inform FANUC of the details of an alarm and the specification code of the amplifier so that any components required for maintenance can be quickly secured, and any other necessary action can be taken without delay.

SAFETY PRECAUTIONS

1. OVERVIEW	1
2. CONFIGURATION	2
2.1 TYPE OF UNIT AND DESIGNATION	3
2.1.1 SVU Types	3
2.1.2 SVUC Types	4
2.1.3 Othes	5
3. SPECIFICATION	8
3.1 SPECIFICATION	9
3.2 PROTECTION AND ERROR DETECTION FUNCTION	12
3.3 NORMAL OPERATION MODE	14
3.4 SWITCH SETTING	15
4. AC LINE FILTER AND SEPARATE REGENERATIVE DISCHARGE UNIT	18
4.1 AC LINE FILTER	19
4.2 SEPARATE REGENERATIVE DISCHARGE UNIT	21
4.2.1 Calculating the Amount of Regenerative Discharge	22
4.2.2 Regenerative Discharge Capacity of Regenerative Discharge Resistor (Built-in and Separate Types)	24
5. POWER SUPPLY	25
5.1 INPUT POWER SUPPLY	26
5.2 POWER REQUIREMENTS	27
5.2.1 Capacity of Three-phase Power Supply	27
5.2.2 Single-phase Input for Control Circuit	28
5.3 POWER TRANSFORMERS FOR EXPORTS	29
5.3.1 Specification	29
5.3.2 How to Select a Transformer	30
5.4 CIRCUIT BREAKER AND MAGNETIC CONTACTOR	31
6. HEAT GENERATION	32
7. INSTALLATION CONDITIONS AND CAUTIONS	35
7.1 ENVIRONMENTAL CONDITIONS	35
7.1.1 Ambient Temperature	35
7.1.2 Humidity	35
7.1.3 Altitude	35
7.1.4 Vibration	35
7.1.5 Atmosphere	35
7.1.6 Cautions for Installation	36
7.2 HOW TO SELECT A GROUND FAULT INTERRUPTER	37
7.3 MEASURES FOR NOISE	38
7.3.1 Signal Line Separation	38
7.3.2 Ground	39
7.3.3 SVU Grounding for CE Marking (EC Machinery Directive)	40

8. OUTLINE DRAWINGS AND AREA OF MAINTENANCE	41
8.1 OUTLINE DRAWINGS AND AREA OF MAINTENANCE	41
8.1.1 Servo Amplifier Unit	41
8.1.2 AC Line Filter	45
8.1.3 Power Transformer for Export	47
8.1.4 Separate Regenerative Discharge Unit	48
8.1.5 Battery Case	51
8.2 PANEL CUTOOUT DRAWING	52
8.2.1 Servo Amplifier Unit	52
8.2.2 Separate Regenerative Discharge Unit	54
9. CONNECTION	56
9.1 OVERVIEW	56
9.1.1 Interface with the NC	56
9.1.2 Safety Standards	56
9.2 BASIC CONNECTION	57
9.2.1 Connection Example for SVU	57
9.2.2 Connection Example for SVUC	61
9.2.3 Connector and Terminal (T1)	63
9.3 DETAILED CONNECTION	65
9.3.1 Detailed Connection of Cable K1	65
9.3.2 Detailed Connection of Cable K2	70
9.3.3 Detailed Connection of Cable K3	77
9.3.4 Detailed Connection of Cable K4	79
9.3.5 Detailed Connection of Cable K5	87
9.3.6 Detailed Connection of Cable K6	88
9.3.7 Detailed Connection of Cable K7	88
9.3.8 Detailed Connection of Cable K8	89
9.3.9 Detailed Connection of Cable K9	91
9.3.10 Detailed Connection of Cable K10	92
9.3.11 Detailed Connection of Cable K11	93
9.3.12 Detailed Connection of Cable K12	94
9.3.13 For installation of the Lightning Surge Protector	95
9.3.14 ESP Signal Connection for Use of Two or more SVUs or SVUCs	97
9.3.15 Monitoring Contact Output	98
10.COMPATIBILITY WITH THE C SERIES SERVO AMPLIFIER	99
10.1 COMPARISON BETWEEN SVU/SVUC AND C SERIES AMPLIFIER	99
10.2 NOTES ON REPLACING A C SERIES AMPLIFIER WITH THE SVUC	102

1

OVERVIEW

This FANUC α series control motor amplifier unit (svu/svuc) is suitable for systems with one or two feed axes.

The features of the servo amplifier unit are as follows:

Compact

The servo amplifier unit is integrated with a power supply. It enables implementation of a compact system with one or two feed axes.

Satisfies safety standards

SVU: The servo amplifier unit is designed to comply with the VDE 0160 (Europe), UL (USA), and CSA (Canada) safety standards.

SVUC: The servo amplifier unit is designed to comply with UL (USA) and CSA (Canada) safety standards. It does not conform to VDE 0160 (Europe) safety standards.

New interfacing capability

The servo amplifier unit provides a new interface (type B) as well as the conventional interface (type A) for the CNC.

Up-to-date power device

The servo amplifier unit uses an up-to-date power device, IPM (intelligent power module), to reduce power loss and enhance alarm detection, thereby increasing its reliability.

Compatibility with the C series amplifier

To maintain compatibility, the servo amplifier unit has the same external shape as the C series amplifier. In addition, they can be mounted in the same manner.

(Some specifications are different, however. See Chapter 10 for details.)

2

CONFIGURATION

Fig. 2 is the configuration of an NC system with two controlled axes. A separate regenerative discharge unit may be required in applications in which the regenerative energy is high.

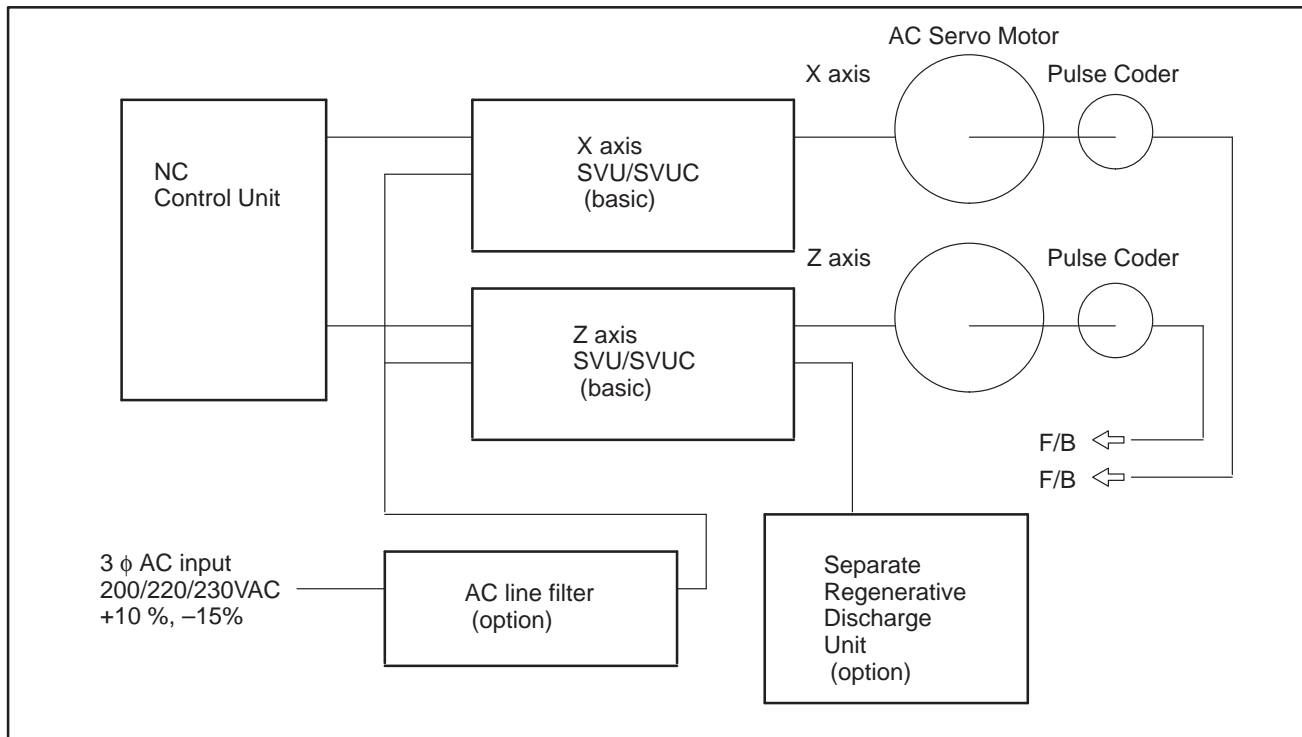

Fig.2 Example of Configuration

2.1 TYPE OF UNIT AND DESIGNATION

2.1.1 SVU Types

Table 2.1.1 (a) Type of SVU and Designation

Group	Axis	Name	Designation	Applied motor group Note 1) (refer to table 2.1.1 (b))	
				L axis	M axis
Basic	1	SVU1-12	A06B-6089-H101	Group A	
		SVU1-20	A06B-6089-H102	Group B	
		SVU1-40	A06B-6089-H104	Group C	
		SVU1-80	A06B-6089-H105	Group D	
		SVU1-130	A06B-6089-H106	Group E	
Basic	2			L axis	M axis
		SVU2-12/12	A06B-6089-H201	Group A	Group A
		SVU2-12/20	A06B-6089-H202	Group A	Group B
		SVU2-20/20	A06B-6089-H203	Group B	Group B
		SVU2-12/40	A06B-6089-H204	Group A	Group F
		SVU2-20/40	A06B-6089-H205	Group B	Group F
		SVU2-40/40	A06B-6089-H206	Group F	Group F
		SVU2-40/80	A06B-6089-H207	Group F	Group G
		SVU2-80/80	A06B-6089-H208	Group G	Group G
		SVU2-12/80	A06B-6089-H209	Group A	Group G
		SVU2-20/80	A06B-6089-H210	Group B	Group G

*Name of Servo Amplifier

· 1-Axis Servo Amplifier SVU1 -□



Limit current value of motor

· 2-Axis Servo Amplifier SVU2 -□ /□



Limit current value of L-axis motor



Limit current value of M-axis motor

Table 2.1.1 (b) Applied motor

Applied motor group	AC Servo Motor
Group A	α 0.5/3000, α 1/3000, α 2/2000, α 2/3000, α E1/3000, α E2/3000
Group B	α C3/2000, α C6/2000, α C12/2000, α E3/2000, α E6/2000
Group C	α 2.5/3000, α 3/3000, α 6/2000, α 12/2000, α C22/1500, α 22/1500, α M3/3000, α L3/3000
Group D	α 6/3000, α 12/3000, α 22/2000, α 30/1200, α M6/3000, α M9/3000, α L6/3000, α L9/3000
Group E	α 22/3000, α 30/2000, α 30/3000, α 40/2000, α 40/2000 (with fan), α L25/3000, α L50/2000
Group F	α 2.5/3000, α 3/3000, α 6/2000, α 12/2000, α L3/3000, α M3/3000
Group G	α 6/3000, α M6/3000

2.1.2 SVUC Types

The SVUC is used to enable maintenance of, or is used as a replacement for, the C series amplifier.

Table 2.1.2 Replacing the C Series Amplifier with the SVUC

Axis	Replacing the C series amplifier with the SVUC	Name
1	A06B-6066-H002 → A06B-6090-H002	SVUC1-4
	A06B-6066-H003 → A06B-6090-H003	SVUC1-12
	A06B-6066-H004 → A06B-6090-H004	SVUC1-40
	A06B-6066-H006 → A06B-6090-H006	SVUC1-80
	A06B-6066-H008 → A06B-6090-H008	SVUC1-130
2	A06B-6066-H222 → A06B-6090-H222	SVUC2-4/4
	A06B-6066-H223 → A06B-6090-H223	SVUC2-4/12
	A06B-6066-H224 → A06B-6090-H224	SVUC2-4/40
	A06B-6066-H233 → A06B-6090-H233	SVUC2-12/12
	A06B-6066-H234 → A06B-6090-H234	SVUC2-12/40
	A06B-6066-H236 → A06B-6090-H236	SVUC2-12/80
	A06B-6066-H244 → A06B-6090-H244	SVUC2-40/40
	A06B-6066-H246 → A06B-6090-H246	SVUC2-40/80
	A06B-6066-H266 → A06B-6090-H266	SVUC2-80/80

The interchangeable C series amplifier and SVUC have identical model names (last nibble) in the drawing numbers. The middle nibbles of the drawing numbers, however, are different: 6066 for the C series amplifier and 6090 for the SVUC.

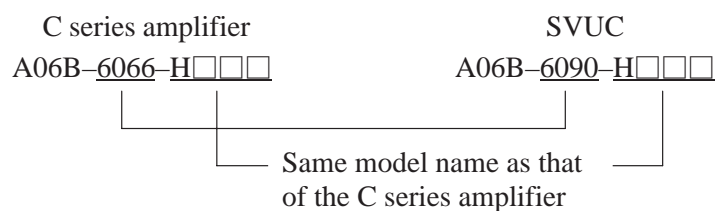

2.1.3 Others

Table 2.1.3 Type of Unit and Designation (1)

Group	Name	Application	Designation
Basic	AC line filter (Caution 1)	Type A: 5.4kW	A81L-0001-0083#3C
		Type B: 10.5kW	A81L-0001-0101#C
		Type C: 23kW	A81L-0001-0102
Option	Power transformer for export (Caution 2)	Type SAE: 2.2kVA	A80L-0022-0005
		Type SBE: 3.5kVA	A80L-0024-0006
		Type SCE: 5.0kVA	A80L-0026-0003
		Type SDE: 7.5kVA	A80L-0028-0001
Option	Separate Regenerative Discharge Unit (Caution 3)	For A06B-6089-H101 to -H102 (16Ω/100W, at natural cooling)	A06B-6089-H510
		For A06B-6089-H101 to -H105, -H201 to -H210, A06B-6090, -H003 to -H006, -H222 to -H266 (16Ω/200W, at natural cooling)	A06B-6089-H500
		For A06B-6089-H104 to -H105, -H201 to -H210, A06B-6090-H004 to -H006, -H222 to -H266 (16Ω/800W, With cooling fanmotor)	A06B-6089-H713
		For A06B-6089-H104 to -H105, -H201 to H210, A06B-6090-H004 to -H006, -H222 to -H266 (16Ω/1200W, With cooling fanmotor)	A06B-6089-H714
		For A06B-6089-H106, A06B-6090-H008 (8Ω/800W, With cooling fanmotor)	A06B-6089-H711
		For A06B-6066-H106, A06B-6090-H008 (8Ω/1200W, With cooling fanmotor)	A06B-6089-H712

Table 2. 1. 3 Type of Unit and Designation (2)

Group	Name	Application	Designation	
Basic	Connector	JV (1/2) B, JS (1/2) B Between NC to SVU/SVUC (Plastic cover) (Note 1)	Soldering type	A06B-6073-K212
			Crimp type	A06B-6073-K213
	Connector	JV (1/2) B, JS (1/2) B Between NC to SVU/SVUC (Metal cover) (Note 1)	Soldering type	A06B-6066-K205
			Crimp type	A06B-6066-K206
	Connector	JF (1/2) For pulse coder F/B cable (Note 1)		A06B-6073-K214
	Connector	CX3 : For external MCC		A06B-6089-K201
	Connector	CX4 : For ESP		A06B-6089-K202
Option	Fuse (Note 2)	For control power supply	A06B-6089-K250	
		For fanmotor (SVU1-130, SVUC1-130)		
	Fanmotor (Note 3)	For SVU1-130, SVUC1-130	A06B-6089-K203	
		Separate Regenerative Discharge Unit (A06B-6089-H711, H712, H713, H714)		
	Battery case	For absolute pulse coder	A06B-6050-K060	
	Battery	For absolute pulse coder	A06B-6050-K061	
	Battery cable	For absolute pulse coder (Length : 5m)	A02B-0120-K809	
	Breaker	5. 0A (*)	A06B-6077-K106	
	Lightning surge protector	(*)	A06B-6077-K141	

* The SVU requires the use of an external circuit breaker and lightning surge protector. The SVUC features a built-in lightning surge protector in the same way as the C series amplifier, hence does not require an external circuit breaker or lightning surge protector.

CAUTION

- 1 Be sure to use an AC line filter in order to reduce harmonic interference with the power supply. See Section 4.1 for details .If a power supply transformer (insulation type) is used for the line voltage out of specification, it can dispense with an AC line filter. If the AC line filter is ineffective in satisfying the EMC standards, use a commercial noise filter.
- 2 If the line voltage is higher than 200/220/230 VAC, use a power transformer. When a transformer is used, an AC line filter usually becomes unnecessary, however in the case that requirements of EMC standard are still not satisfied, AC line filter will be needed.
- 3 If the load inertia or the frequency of acceleration/ deceleration is high, and the regenerative discharge energy from the motor exceeds a specified value, separate regenerative discharge unit should be used. If the heat dissipation is higher than a specified value of a separate regenerative discharge unit, please check the servo motor selection and consult FANUC. See Section 4.2 for details.

NOTE

- 1 This amplifier has two types of NC interfaces. Type A interface requires JV (1/2) B. Type B interface requires JS (1/2) B or JF (1/2) .
- 2 The specification of the spare fuses is common to both the control power supply and fanmotors. A fanmotor fuse is built only in SVU1-130 (A06B-6089-H106) and SVUC1-130 (A06B-6090-H008).
- 3 SVU1-130 (A06B-6089-H106), SVUC1-130 (A06B-6090-H008) and a separate regenerative discharge unit (A06B-6089-H711 to -H714) with a cooling fan contains a fanmotor. A fanmotor should be arranged as a spare part.
- 4 Use the following servo amplifiers for the T series motors (hollow-type motors) .
Model 0T/3000 => Amplifier corresponding to α 3/3000
Model 5T/2000 => Amplifier corresponding to α 6/2000
Model 5T/3000 => Amplifier corresponding to α 6/3000
Model 10T/2000 => Amplifier corresponding to α 12/2000
Model 10T/3000 => Amplifier corresponding to α 12/3000

3

SPECIFICATION



3.1 SPECIFICATION

Table 3.1 (a) Specification (Common)

Item		Specification
Power supply	Three-phase input for power (Caution 1)	Voltage : 200/220/230 VAC +10 %, -15 % Frequency : 50/60Hz \pm 2Hz Voltage deviation due to load (at maximum output) shall be 7% or less.
	Single-phase input for control power (Caution 1)	Voltage : 200/220/230 VAC +10 %, -15 % Frequency : 50/60Hz \pm 2Hz
	Single-phase input emergency stop (Caution 2)	Voltage : 100 VAC +10 %, -15 % Frequency : 50/60Hz Voltage : 110 VAC +10 %, -15 % Frequency : 60Hz
Control of main circuit		Sine-wave PWM control by transistor bridge (IPM)
Alarm and protection functions		<ul style="list-style-type: none"> • Over-voltage alarm • Low control power voltage alarm • Low DC link voltage alarm • Regenerative discharge control circuit failure alarm • Over-regenerative discharge alarm • Dynamic brake circuit failure alarm • Over-current alarm • IPM alarm • Circuit breaker
Contact of the relay of the Dynamic brake circuit (Caution 3)		<ul style="list-style-type: none"> ● Except SVU1-130, SVUC1-130 • In dynamic brake, its contact is short. • Condition to use the contact 24VDC, more than 10mA less than 0.3A ● SVU1-130, SVUC1-130 • In dynamic brake, its contact is open. • Condition to use the contact 24VDC, more than 10mA less than 0.3A

CAUTION

- 1 Two lines of the three-phase input for power were connected with the lines of the single-phase input for control power by a jumper bar at the factory.
- 2 Necessary for the SVUC only
- 3 The customer can use this contact for monitoring purposes when designing a safety protection circuit.

Table 3.1 (b) Specification (Each model for SVU)

Axis	Name	Designation	L axis		M axis	
			Rated current (Arms)	Current limit (Apeak)	Rated current (Arms)	Current limit (Apeak)
1	SVU1-12	A06B-6089-H101	3.0	12		
	SVU1-20	A06B-6089-H102	5.9	20		
	SVU1-40	A06B-6089-H104	12.5	40		
	SVU1-80	A06B-6089-H105	18.7	80		
	SVU1-130	A06B-6089-H106	52.2	130		
2	SVU2-12/12	A06B-6089-H201	3.0	12	3.0	12
	SVU2-12/20	A06B-6089-H202	3.0	12	5.9	20
	SVU2-20/20	A06B-6089-H203	5.9	20	5.9	20
	SVU2-12/40	A06B-6089-H204	3.0	12	8.8	40
	SVU2-20/40	A06B-6089-H205	5.9	20	8.8	40
	SVU2-40/40	A06B-6089-H206	8.8	40	8.8	40
	SVU2-40/80	A06B-6089-H207	8.8	40	10.0	80
	SVU2-80/80	A06B-6089-H208	10.0	80	10.0	80
	SVU2-12/80	A06B-6089-H209	3.0	12	10.0	80
	SVU2-20/80	A06B-6089-H210	5.9	20	10.0	80

CAUTION

- 1 The rated output is guaranteed under the rated input voltage. When the input voltage fluctuates, the rated output may not be obtained even if the fluctuation is within the tolerance.
- 2 The current limit are those typical. The operating value may vary by about $\pm 10\%$ due to varying circuit parameters.

Table 3.1 (c) Specification (Each model)

Axis	Name	Designation	L axis		M axis	
			Rated current (Arms)	Current limit (Apeak)	Rated current (Arms)	Current limit (Apeak)
1	SVUC1-4	A06B-6090-H002	0.9	4		
	SVUC1-12	A06B-6090-H003	2.9	12		
	SVUC1-40	A06B-6090-H004	16.0	40		
	SVUC1-80	A06B-6090-H006	20.0	80		
	SVUC1-130	A06B-6090-H008	51.0	130		
2	SVUC2-4/4	A06B-6090-H222	0.9	4	0.9	4
	SVUC2-4/12	A06B-6090-H223	0.9	4	2.9	12
	SVUC2-4/40	A06B-6090-H224	0.9	4	8.7	40
	SVUC2-12/12	A06B-6090-H233	2.9	12	2.9	12
	SVUC2-12/40	A06B-6090-H234	2.9	12	8.7	40
	SVUC2-12/80	A06B-6090-H236	2.9	12	10.2	80
	SVUC2-40/40	A06B-6090-H244	8.7	40	8.7	40
	SVUC2-40/80	A06B-6090-H246	8.7	40	10.2	80
	SVUC2-80/80	A06B-6090-H266	10.2	80	10.2	80

CAUTION

- 1 The rated output is guaranteed under the rated input voltage. When the input voltage fluctuates, the rated output may not be obtained even if the fluctuation is within the tolerance.
- 2 The current limit are those typical. The operating value may vary by about $\pm 10\%$ due to varying circuit parameters.

3.2 PROTECTION AND ERROR DETECTION FUNCTION

The servo amplifier has a protection and error detection function. The detected alarm conditions are indicated by the 7-segment LED on the front of the servo amplifier.

If an alarm occurs, the motor is forced to stop by a dynamic brake.

Table 3.2 Protection and Error Detection Function (1/2)









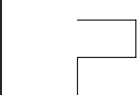

Type	LED indication	Description
Over-voltage alarm (HV)		This alarm occurs if the DC voltage of the main circuit power supply is abnormally high.
Low control power voltage alarm (LV)		This alarm occurs if the control power voltage is abnormally low.
Low DC link voltage alarm (LVDC)		This alarm occurs if the DC voltage of the main circuit power supply is abnormally low or the circuit breaker trips.
Regenerative discharge control circuit failure alarm (DCSW)		This alarm occurs if: – The short-time regenerative discharge energy is too high. – The regenerative discharge circuit is abnormal.
Over-regenerative discharge alarm (DCOH)		This alarm occurs if: – The average regenerative discharge energy is too high (too frequent acceleration/deceleration). – The transformer overheats. (See 9.3.8)
Dynamic brake circuit failure alarm (DBRLY)		This alarm occurs if the relay contacts of the dynamic brake welds together.

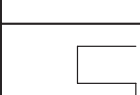
Table 3.2 Protection and Error Detection Function (2/2)

Type	LED indication	Description
L-axis over-current alarm (HCL)		This alarm occurs if an abnormally high current flows in the L-axis motor.
M-axis over-current alarm (HCM)		This alarm occurs if an abnormally high current flows in the M-axis motor.
L-and M-axis over-current alarm (HCLM)		This alarm occurs if an abnormally high current flows in the L-and M-axis motors.
L-axis IPM alarm (IPML)		This alarm is detected by the IPM (intelligent power module) of the L-axis. (Note 1)
M-axis IPM alarm (IPMM)		This alarm is detected by the IPM (intelligent power module) of the M-axis. (Note 1)
L-and M-axis IPM alarm (IPMLM)		This alarm is detected by the IPM (intelligent power module) of the L-and M-axes. (Note 1)
Circuit breaker	Trips	The circuit breaker trips if an abnormally high current (exceeding the working current of the circuit breaker) flows through it.



NOTE

- 1 The IPM can detect the following alarms.
 - Over-current
 - Over-heat
 - Drop in IPM control power voltage
- 2 When the control power is separated from the main power, if the circuit breaker for the servo amplifier is off, low DC link voltage alarm (LVDC) is detected.

3.3 NORMAL OPERATION MODE

In the normal operation mode, the 7-segment LED on the front of the servo amplifier lights as listed below.

Table 3.3 Normal Operation Mode

Type	LED indication	Description
Amplifier not ready		Indicates that the servo amplifier is not ready to drive the motor.
Amplifier ready		Indicates that the servo amplifier is ready to drive the motor.

3.4 SWITCH SETTING

There are four channel switches above the 7-segment LED behind the terminal board cover on the front of the servo amplifier. These switches should be set as described below before use of the servo amplifier.

(1) Positions

The switches are sequentially numbered 1, 2, 3, and 4 with the one at the bottom as switch 1. The OFF position is on the left, and the ON position on the right.

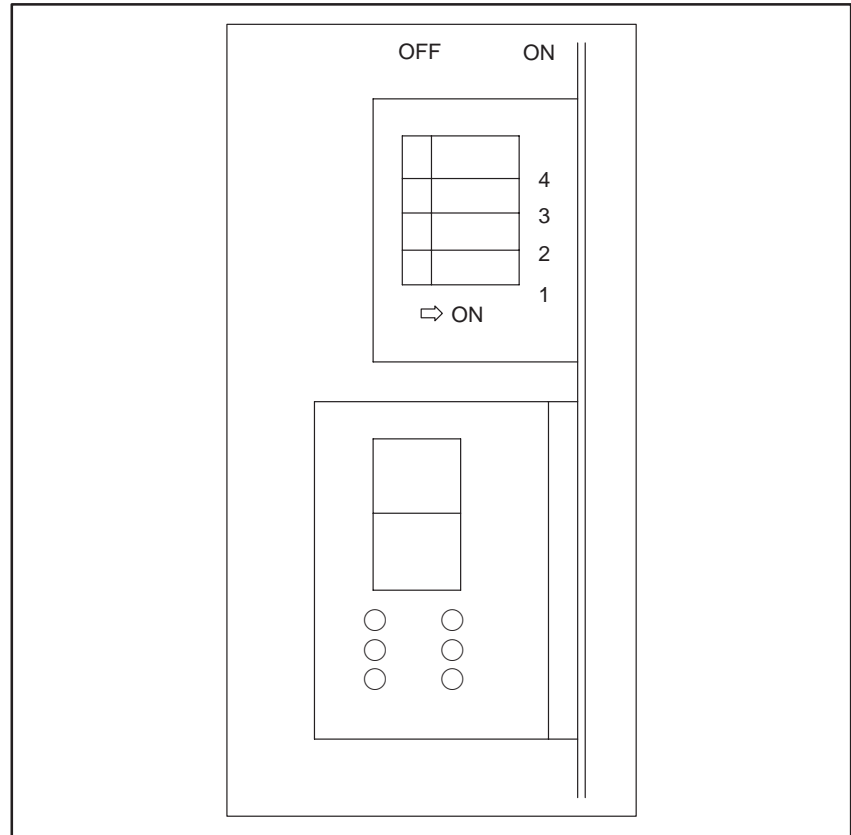

(2) Switch 1 setting

The setting of switch 1 varies with the interface type used between the NC and servo amplifier.

- ⇒ If the setting is incorrect, an alarm occurs.
If the load is light, the motor may keep running.

Switch 1 setting	
ON	Type B interface
OFF	Type A interface

- The following NC unit has the type A interface.
Series 0-C, Series15-A, Series15-B, Series 16-A, Series 16-B, Series 18-A, Series 21-TA, Power Mate-D, Power Mate-F
- The following NC unit has the type B interface.
Series 20-A, Series 21-TB, Series 21-GA, Series 16-B, Series 18-B, Power Mate-H

(3) Switch 2 setting

The settings of the SVU and SVUC differ.

Switch 2 setting	
ON	SVUC
OFF	SVU

⇒ If the setting is incorrect, the VRDY OFF alarm may occur.

(4) Switch 3 and 4 setting

The setting varies depending on the regenerative discharge resistance used.

⇒ If the setting is incorrect, the regenerative discharge control circuit failure alarm (DCSW) cannot be detected correctly.

(a) SVU1 – 12, 20

SW3	SW4	Regenerative Discharge Resistor
ON	ON	Built-in (20W)
ON	OFF	Separate A06B-6066-H510 (100W), A06B-6089-H510 (100W)
OFF	OFF	Separate A06B-6066-H500 (200W), A06B-6089-H500 (200W)

(b) SVUC1 – 4, 12

SW3	SW4	Regenerative Discharge Resistor
ON	ON	Built-in (20W)

(c) SVU1 – 40, 80, SVU2 – □/□
SVUC1 – 40, 80, SVUC2 – □/□

SW3	SW4	Regenerative Discharge Resistor
ON	ON	Built-in (100W)
ON	OFF	Separate A06B-6066-H500 (200W), A06B-6089-H500 (200W)
OFF	OFF	Separate A06B-6066-H713 (800W), A06B-6066-H714 (1200W), A06B-6089-H713 (800W), A06B-6089-H714 (1200W)

(d) SVU1 –130, SVUC1–130

SW3	SW4	Regenerative Discharge Resistor
ON	ON	Built-in (400W)
ON	OFF	Separate A06B-6066-H711 (800W), A06B-6089-H711 (800W)
OFF	OFF	Separate A06B-6066-H712 (1200W), A06B-6089-H712 (1200W)

NOTE

The separate regenerative discharge resistor, designated A06B-6066-H***, does not comply with European safety standards (VDE 0160). To allow the application of the CE marking (machinery directive), use the separate regenerative discharge resistor designated A06B-6089-H***, which fully conforms to European safety standards.

4

AC LINE FILTER AND SEPARATE REGENERATIVE DISCHARGE UNIT



4.1 AC LINE FILTER

An AC line filter should be used to reduce the effect of harmonic noise to the power supply. If two or more servo amplifiers are connected to one AC line filter, the total continuous output rating of all the connected servo amplifiers should be kept below the continuous output rating of the AC line filter.

Estimation of total continuous output rating of the servo motors can be reduced depending on the load conditions.

[Example of selecting an AC line filter]
 Motors : $\alpha 12/2000 + \alpha 12/2000 + \alpha 22/2000$

1. Continuous output rating of each servo motor
 $\alpha 12/2000$: 2.1 kW
 $\alpha 22/2000$: 3.8 kW
2. Total continuous output rating of the servo motors
 $2.1+2.1+3.8=8.0$ kW
3. Select the type B AC line filter, whose maximum continuous output rating is 10.5 kW.

Table 4.1(a) AC Line Filter Specification

AC line filter	Continuous rated current	Continuous output rating	Heat generation
Type A: A81L-0001-0083#3C	24A	5.4kW Max.	20W
Type B: A81L-0001-0101#C	44A	10.5kW Max.	70W
Type C: A81L-0001-0102	100A	23.0kW Max.	50W

Table 4.1(b) Continuous output rating of servo motors

Motor Model	Continuous output rating	Motor Model	Continuous output rating	Motor Model	Continuous output rating
α 0.5/3000	0.2 kW	α 22/3000	4.4 kW	α M3/3000	0.9 kW
α 1/3000	0.3 kW	α 30/1200	3.3 kW	α M6/3000	1.4 kW
α 2/2000	0.4 kW	α 30/2000	4.5 kW	α M9/3000	1.8 kW
α 2/3000	0.5 kW	α 30/3000	4.8 kW	α C3/2000	0.3 kW
α 2.5/3000	0.3 kW	α 40/2000	5.9 kW	α C6/2000	0.6 kW
α 3/3000	0.9 kW	α 40/2000 with fan	7.3 kW	α C12/2000	1.0 kW
α 6/2000	1.0 kW	α E1/3000	0.3 kW	α C22/1500	1.5 kW
α 6/3000	1.4 kW	α E2/3000	0.5 kW	α L3/3000	0.9 kW
α 12/2000	2.1 kW	α E3/2000	0.5 kW	α L6/3000	1.4 kW
α 12/3000	2.8 kW	α E6/2000	0.9 kW	α L9/3000	2.0 kW
α 22/1500	3.0 kW			α L25/3000	3.5 kW
α 22/2000	3.8 kW			α L50/2000	6.0 kW

4.2 SEPARATE REGENERATIVE DISCHARGE UNIT

- (1) If a servo motor releases a large amount of regenerative discharge, which exceeds the regenerative discharge capacity of the regenerative discharge resistor in the servo amplifier, it is necessary to use a separate regenerative discharge unit.
- (2) If the motor regenerative discharge R calculated in Subsec. 4.2.1 for each axis exceeds the regenerative discharge capacity of the regenerative discharge resistor in the servo amplifier listed in Table 4.2.2 (a), use a separate regenerative discharge unit. If R exceeds also the regenerative discharge capacity of the regenerative discharge resistor in the separate regenerative discharge unit listed in Table 4.2.2 (b), contact FANUC and ask for information. (If a machine has a high holding torques on its vertical axis with no counter balance, a large amount of high regenerative discharge occurs when the load moves down along the vertical axis. In such a case, especially if the machine has a long stroke and the load descends rapidly, the amount of generated regenerative discharge may exceed the regenerative discharge capacity of the separate regenerative discharge unit.)
- (3) The regenerative discharge capacity of the regenerative discharge resistor in the following units can be increased by cooling the resistor with an external cooling fan: separate regenerative discharge units A06B-6089-H510 and H500, and servo amplifiers (A06B-6089-H104, H105, and H201 to H210) and (A06B-6090-H004, H006, and H222 to H266).
Tables 4.2.2 (a) and (b) list the relationships between the speed of cooling air flow and the regenerative discharge capacity.
- (4) The separate regenerative discharge units listed in Table 4.2.2 (b) have been developed for use with the α series servo amplifier units. These discharge units comply with European safety standards (VDE 0160). The separate regenerative discharge units for the C series servo amplifier units can be used for the α series servo amplifier units. However they have not been designed to meet the requirements of the European standards.

NOTE

The CE marking (machinery directive) cannot be affixed to a machine using the SVUC.

4.2.1 Calculating the Amount of Regenerative Discharge

The amount (R) of regenerative discharge of a motor is the sum of P and Q calculated in Section (i) and (ii), respectively.

$$R = P + Q \text{ [W]} \dots\dots\dots (1)$$

(i) Horizontal operation

Amount of regenerative discharge (power [W]) with a rapid-traverse acceleration/deceleration frequency of one per F seconds

SI system of units

$$P = \frac{1}{F} \times (5.48 \times 10^{-3} \text{ J Vm}^2 - 5.23 \times 10^{-2} \text{ ta Vm TL}) \text{ [W]} \dots (2)$$

where

F: Rapid-traverse acceleration/deceleration frequency
(sec/occurrence)

CAUTION

Unless otherwise specified, "once per five seconds" is assumed.

J: $J_m + J_L$

J_m : Inertia ($\text{kg} \cdot \text{m}^2$) of the motor rotor

J_L : Load inertia ($\text{kg} \cdot \text{m}^2$) in terms of motor shaft inertia

V_m : Motor speed (min^{-1}) for rapid traverse

t_a : Rapid-traverse acceleration/deceleration time (sec)

T_L : Machine friction torque (in terms of motor shaft torque) ($\text{N} \cdot \text{m}$)

CGS system of units

$$P = \frac{1}{F} \times (5.37 \times 10^{-4} \text{ J Vm}^2 - 5.13 \times 10^{-3} \text{ ta Vm TL}) \text{ [W]} \dots (3)$$

where

F: Rapid-traverse acceleration/deceleration frequency
(sec/occurrence)

CAUTION

Unless otherwise specified, "once per five seconds" is assumed.

J: $J_m + J_L$

J_m : Inertia ($\text{kg} \cdot \text{cm} \cdot \text{sec}$) of the motor rotor

J_L : Load inertia ($\text{kg} \cdot \text{cm} \cdot \text{sec}$) in terms of motor shaft inertia

V_m : Motor speed (rpm) for rapid traverse

t_a : Rapid-traverse acceleration/deceleration time (sec)

T_L : Machine friction torque (in terms of motor shaft torque) ($\text{kg} \cdot \text{cm}$)

(ii) Vertical operation

Amount of regenerative discharge (power [W]) with a duty cycle D (%) in the rapid-traverse descending direction

SI system of units

$$Q = 1.047 \times 10^{-1} Th Vm \times \frac{D}{100} [W] \dots\dots\dots (4)$$

where

Th: Torque (N · m) needed for the motor to change the operation from rapid traverse descending to ascending

Vm: Motor speed (min⁻¹) for rapid traverse

D: Duty cycle (%) during rapid-traverse descending

CAUTION
D is 50% at most. It is usually below 50%.

CGS system of units

$$Q = 1.026 \times 10^{-2} Th Vm \times \frac{D}{100} [W] \dots\dots\dots (5)$$

where

Th: Torque (kg · cm) needed for the motor to change the operation from rapid traverse descending to ascending

Vm: Motor speed (rpm) for rapid traverse

D: Duty cycle (%) during rapid-traverse descending

CAUTION
D is 50% at most. It is usually below 50%.

4.2.2 Regenerative Discharge Capacity of Regenerative Discharge Resistor (Built-in and Separate Types)

Table 4.2.2 (a) Regenerative discharge capacity of built-in type discharge resistor

Servo Amplifier	No wind	wind velocity 2m/sec	wind velocity 4m/sec
A06B-6089-H101 A06B-6089-H102 A06B-6090-H002 A06B-6090-H003	R=20W	—————	—————
A06B-6089-H104 A06B-6089-H105 A06B-6089-H201 to -H210 A06B-6090-H004 A06B-6090-H006 A06B-6090-H222 to -H266	R=100W	R=200W	R=300W
A06B-6089-H106 A06B-6090-H008	Forced cooling fanmotor is installed		R=400W

Table 4.2.2 (b) Regenerative discharge capacity of separate regenerative discharge unit

Separate regenerative discharge unit	No wind	wind velocity 2m/sec	wind velocity 4m/sec
A06B-6089-H510 (16Ω)	R=100W	R=250W	—————
A06B-6089-H500 (16Ω)	R=200W	R=400W	R=600W
A06B-6089-H713 (16Ω)	Forced cooling fanmotor is installed		R=800W
A06B-6089-H714 (16Ω)	Forced cooling fanmotor is installed		R=1200W
A06B-6089-H711 (16Ω)	Forced cooling fanmotor is installed		R=800W
A06B-6089-H712 (8Ω)	Forced cooling fanmotor is installed		R=1200W

5

POWER SUPPLY



5.1 INPUT POWER SUPPLY

- Nominal rated voltage: 200/220/230 VAC
- Voltage fluctuation tolerance: -15% to +10%
- Frequency: 50/60 Hz
- Frequency fluctuation tolerance: ± 2 Hz
- Power supply impedance: Voltage drop of 7% or less due to load
(at maximum output)
- Power supply unbalance: +5% or less of rated voltage

Cautions in connecting the power supply

The servo amplifier requires a three-phase input for power and a single-phase input for control power. Two lines of the three-phase input for power were connected with the lines of the single-phase input for control power by a jumper bar on terminal board T1 at the factory. If you want to separate the two power supplies, remove the jumper bar.

5.2 POWER REQUIREMENTS

5.2.1 Capacity of Three-phase Power Supply

- (1) If more than one servo motor is used, the total power requirement can be calculated by adding the requirements of all the servo motors.
- (2) As for continuous output ratings, the power requirements listed in Table 5.2.1 are sufficient. However, when a servo motor is required to accelerate sharply, it may momentarily consume power twice as more as the continuous output rating.

So, check the amplifier input voltage during simultaneous acceleration/deceleration of the servo motors. The voltage should be at least 170 VAC (200 VAC –15%).

Table 5.2.1 Power requirements for motor

motor model	Power requirements per motor	motor model	Power requirements per motor	motor model	Power requirements per motor
α0.5/3000	0.31 kVA	α22/3000	6.8 kVA	αM3/3000	1.4 kVA
α1/3000	0.46 kVA	α30/1200	5.1 kVA	αM6/3000	2.2 kVA
α2/2000	0.62 kVA	α30/2000	7.7 kVA	αM9/3000	2.8 kVA
α2/3000	0.77 kVA	α30/3000	8.2 kVA	αC3/2000	0.46 kVA
α2.5/3000	0.77 kVA	α40/2000	9.1 kVA	αC6/2000	0.93 kVA
α3/3000	1.4 kVA	α40/2000 (with fan)	11.3 kVA	αC12/2000	1.6 kVA
α6/2000	1.5 kVA	αE1/3000	0.46 kVA	αC22/1500	2.3 kVA
α6/3000	2.2 kVA	αE2/3000	0.77 kVA	αL3/3000	1.4 kVA
α12/2000	3.3 kVA	αE3/2000	0.77 kVA	αL6/3000	2.2 kVA
α12/3000	4.3 kVA	αE6/2000	1.4 kVA	αL9/3000	3.1 kVA
α22/1500	4.7 kVA			αL25/3000	5.4 kVA
α22/2000	5.9 kVA			αL50/2000	9.3 kVA

5.2.2 Single-phase Input for Control Circuit

Table 5.2.2 Power requirements for control circuits

Servo Amplifier	Capacity
A06B-6089-H101 to H105 A06B-6090-H002 to H006	30 VA
A06B-6089-H106 A06B-6090-H008	60 VA
A06B-6089-H201 to H210 A06B-6090-H222 to H266	40 VA

5.3 POWER TRANSFORMERS FOR EXPORTS

Use a power transformer for an export when this servo amplifier unit is used at a site where the line voltage is other than 200/220/230 VAC.

5.3.1 Specification

Table 5.3.1 Specification of power transformers

Designation	A80L-0022-0005	A80L-0024-0006	A80L-0026-0003	A80L-0028-0001
Model	SAE	SBE	SCE	SDE
Rated capacity	2.2 kVA	3.5 kVA	5.0 kVA	7.5 kVA
Rated primary voltage	200/220/230/240VAC (delta connection) 380/415/460/480/550VAC (star connection) +10%; -15%, 50/60Hz ±2Hz, 3φ			
rated secondary voltage	210VAC			
Rated secondary current	6.1 A	9.6 A	13.7 A	20.6 A
Secondary voltage regulation	5 %			
Secondary voltage deviation	± 2 %			
Connection	delta-delta-connection or star-delta connection			
Insulation	Class B (Max. temperature 130°C)			
Ambient temp.	-20 to 55 °C			
Allowable temperaturerise	135 °C			
Humidity	Max. 95%RH			
Type	dry-type, self-cooling			
Dielectric voltage	2300VAC, 1 minute			
Wight	Max. 21kg	Max. 27kg	Max. 36kg	Max. 42kg
External dimensions	See section 8.1.3			
Connection				

5.3.2 How to Select a Transformer

Select a transformer according to the load condition and the model of the motor for which the transformer is used. Each transformer has secondary winding taps for three amplifiers so that it can be connected to two or three amplifiers.

For a machine with typical operating conditions, select a transformer according to the following guideline.

$$(\text{Sum of 3-phase power requirements of all motors}) \times 0.6 \geq \text{transformer rating}$$

Table 5.2.1

Table 5.3.1

CAUTION

When two or more motors are used, the transformer rating obtained using the above expression may be less than the actual power requirements of any one of those motors. Should this occur, use the motors' maximum power requirements as the transformer rating.

(Example) The power requirements of the $\alpha 22/2000$ and $\alpha 40/2000$ (with fan) are indicated in Table 5.2.1, as shown below:

$\alpha 22/2000$:	5.9 kVA
$\alpha 40/2000$ (with fan)	:	11.3 kVA

Using the expression given above, the transformer rating is calculated as follows:

$$(5.9 + 11.3) \times 0.6 = 10.32 \text{ kVA}$$

The power requirement of the $\alpha 40/2000$ (with fan) is 11.3 kVA, this being greater than the calculated transformer rating of 10.32 kVA. So, the transformer rating should be 11.3 kVA.

5.4 CIRCUIT BREAKER AND MAGNETIC CONTACTOR

The current drawn by the SVU/SVUC is obtained using the following expression. Use the calculated value as a reference value when selecting an external magnetic contactor (MCC), power cable, and so on.

$$\text{Input current (Arms)} = \frac{\text{Power supply rating (kVA)}}{\sqrt{3} \times \text{Rated supply voltage}} \times 1.2 \text{ (Margin)}$$

CAUTION

The rated supply voltage will normally be 200 Vrms.

6

HEAT GENERATION

- (1) The heat generated by a servo amplifier unit can be calculated by the following equations. In calculation, use appropriate values selected from Tables 6.1 and 6.2 according to the models of the amplifier and motor to be used.

		Value determined depending on the motor for the second axis		
		Value determined depending on the motor for the first axis		
		Value determined depending on the unit		
		↓	↓	↓
Total heat generation	(W) = a +	(c+d)	+	(c+d)
Heat generated in the cabinet (cooling by natural air flow)	(W) = b +	(0.2c+d)	+	(0.2c+d)
Heat generated in the cabinet (cooling by forced air flow)	(W) = b +	(0.1c+d)	+	(0.1c+d)

(Example) When the SVU2-20/40 is used to drive the C12/2000 and C22/1500, the generated heat is calculated as follows:

Each heat generation SVU2-20/40 a=29.8 b=29.8
 α C12/2000 c=27.3 d=3.8
 α C22/1500 c=53.0 d=8.6

Total heat generation=
 $29.8 + (27.3+3.8) + (53.0+8.6) = 122.5$
 Heat generated in the cabinet =
 $29.8 + (0.2 \times 27.3+3.8) + (0.2 \times 53.0+8.6) = 58.3$
 (cooling by natural air flow)
 Heat generated in the cabinet =
 $29.8 + (0.1 \times 27.3+3.8) + (0.1 \times 53.0+8.6) = 50.2$
 (cooling by forced air flow)

- (2) The amounts of generated heat listed above apply when all motors run at the respective continuous output ratings. These values may be decreased during cabinet design, depending on the actual operating condition.
- (3) The servo amplifier heat sinks can be placed outside the cabinet (except for some models). This configuration can reduce the heat generated within the cabinet. The amount of heat generated in the cabinet varies depending on whether the heat sink is cooled by natural or forced air flow.

CAUTION

Cooling by forced air flow uses a air flow speed of 2 m/s measured at the heat sink. Servo amplifier unit A06B-6089-H106 or A06B-6090-H008 has a standard built-in cooling fan.

(4) Heat generated by the regenerative discharge resistor

- The regenerative discharge resistor built in servo amplifier A06B-6089-H101/H102 or A06B-6090-H002/H003 cannot be placed outside the cabinet because of its structure. Therefore, the amount of heat generated in the resistor must be added to the total heat generated in the cabinet. See Section 4.2 for descriptions of the heat generated by the regenerative discharge resistor.
- The regenerative discharge resistor built in a servo amplifier other than A06B-6089-H101/H102 or A06B-6090-H002/H003 can be placed outside the cabinet by putting its heatsink out of the cabinet. In this case, it is unnecessary to add the heat generated by the regenerative discharge resistor to the total heat generated in the cabinet.
- If a separate regenerative discharge resistor unit is placed outside the cabinet, it is unnecessary to add the heat generated by the regenerative discharge resistor to the total heat generated in the cabinet.
- If the heat sink of a servo amplifier unit or a separate regenerative discharge resistor unit is in the cabinet, it is necessary to add the heat generated by the regenerative discharge resistor to the total heat generated in the cabinet. See Section 4.2 for descriptions of the heat generated by the regenerative discharge resistor.

Table 6 (a) Total heat generation of each servo amplifier

amplifier model	Total heat generation (W) : a	Heat generation in the cabinet (W) : b
SVU1-12, 20 SVUC1-4, 12	20.6	20.6
SVU1-40, 80 SVUC1-40, 80	26.1	26.1
SVU1-130 SVUC1-130	59.3	37.3
All SVU2 models All SVUC2 models	29.8	29.8

Table 6 (b) Heat generation depending on the motors

motor model	total heat generation (W) : c	total heat generation (W) : d
α0.5/3000	10.8	1.4
α1/3000	9.9	1.0
α2/2000	10.4	0.9
α2/3000	13.8	1.7
α2.5/3000	19.9	2.2
α3/3000	22.3	1.2
α6/2000	26.3	1.7
α6/3000	44.0	2.8
α12/2000	45.5	4.3
α12/3000	73.2	6.6
α22/1500	64.8	8.6
α22/2000	91.6	9.6
α22/3000	157.9	0
α30/1200	67.5	4.4
α30/2000	108.9	0
α30/3000	168.2	0
α40/2000	148.6	0
α40/2000 (with fan)	216.9	0
αM3/3000	24.6	1.5
αM6/3000	37.4	1.8
αM9/3000	48.5	3.0
αC3/2000	11.6	0.9
αC6/2000	16.6	1.4
αC12/2000	27.3	3.8
αC22/1500	53.0	8.6
αL3/3000	26.5	1.9
αL6/3000	49.3	3.7
αL9/3000	72.5	8.1
αL25/3000	176.0	0
αL50/2000	265.6	0
αE1/3000	11.9	1.5
αE2/3000	13.2	1.4
αE3/2000	22.1	4.9
αE6/2000	24.6	3.1

7

INSTALLATION CONDITIONS AND CAUTIONS

7.1 ENVIRONMENTAL CONDITIONS

The servo amplifier unit should be installed in a place meeting the following environmental conditions.

7.1.1 Ambient Temperature

Temperature around the unit : 0 to 55 °C (during operation)
-20 to 60 °C (during storage or shipment)

Temperature change ratio : 1.1 °C /min or less

7.1.2 Humidity

Relative humidity of 30 to 95% with no condensation

7.1.3 Altitude

Not higher than 1000 m above the sea

7.1.4 Vibration

0.5 G or less during operation

7.1.5 Atmosphere

Corrosive or conductive mist or water drop may not stick to the electronic circuit or the heat sink.

7.1.6 Cautions for Installation

The servo amplifier unit is designed for installation in the machine magnetics cabinet with the heat sink protruding from the rear of the cabinet so that the heat generated in the semiconductors is released outside the cabinet to minimize the heat remaining in the cabinet. So, observe the following items when installing the servo amplifier unit.

- (1) Be careful not allow dielectric fluid, oil mist, or cutting chips to attach to the heat sink or fan. Such foreign matter may decrease the cooling efficiency and prevent the normal operation of the servo amplifier unit.

In addition, the life of the semiconductors in the amplifier may be adversely affected. If the machine magnetics cabinet is designed to take in outside air, use an air filter at the air inlet. Also seal the cable access holes and door of the cabinet securely.

- (2) Protect the main body of the servo amplifier unit from contaminants (such as dust, coolant, organic solvent, acid, corrosive gas, and salt) by keeping it in a cabinet. When it is used in an environment where it may be exposed to radiations (such as microwave, ultraviolet ray, laser beam, and X-ray), take a necessary provision to shut out the radiations.
- (3) Keep dust or dielectric fluid from entering an air outlet without disturbing the cooling air flow.
- (4) Take precautions to facilitate inspection, dismounting, and mounting of the servo amplifier unit for maintenance.
- (5) Separate the current carrying lines from the signal lines, and take measures for noise. For details, see Section 7.3 and refer to the appropriate CNC connection manual.

7.2 HOW TO SELECT A GROUND FAULT INTERRUPTER

Because the α series control motor amplifiers drive motors using a transistor PWM inverter, high-frequency current leaks to a ground line through a stray capacitance between the motor winding, power cable, or amplifier and the ground line. This current may cause a ground fault interrupter or leakage protection relay to malfunction. To prevent such a malfunction, use a ground fault interrupter designed for use with an inverter. The values listed in the following table indicate the approximate leakage current of each motor.

Motor model	Commercial power frequency component
$\alpha 0.5$ to $\alpha 6$	1.8 mA
$\alpha 12$ to $\alpha 22$	2.0 mA
$\alpha 30$ to $\alpha 40$	2.5 mA

7.3 MEASURES FOR NOISE

7.3.1 Signal Line Separation

Separate the signal lines from the amplifier input power lines and motor power lines. The types of cables used are as follows:

Group	Description	Measure
A	Amplifier input power line	Bundle the cables in group A separated from those in group B at least 10 cm, or isolate the groups from each other by placing a grounded metal (ferrous) plate between them. Attach a noise suppressor such as a spark killer to the coil of MCC.
	Motor power line	
	Coil of MCC	
B	CNC-SVU/SVUC cable	Bundle the cables in group A separated from those in group B at least 10 cm, or isolate the groups from each other by placing a grounded metal (ferrous) plate between them. And be sure to shield this group.
	Pulse coder feedback cable	

NOTE

- 1 "To bundle separately" means "to maintain a separation of at least 10 cm between the cable groups."
- 2 "To isolate" means "to place a grounded metal (ferrous) plate between the groups."

7.3.2 Ground

The following ground systems are provided for CNC machine tool.

- (a) Signal ground system (SG)
The signal ground (SG) supplies the reference voltage (0V) of the electrical signal system.
- (b) Frame ground system (FG)
The frame ground system (FG) is used for safety, and suppressing external and internal noises. In the frame ground system, the frames, cases of the units, panels, and shields for the interface cables between the units are connected.
- (c) System ground system
The system ground system is used to connect the frame ground systems connected between devices or units with the ground.

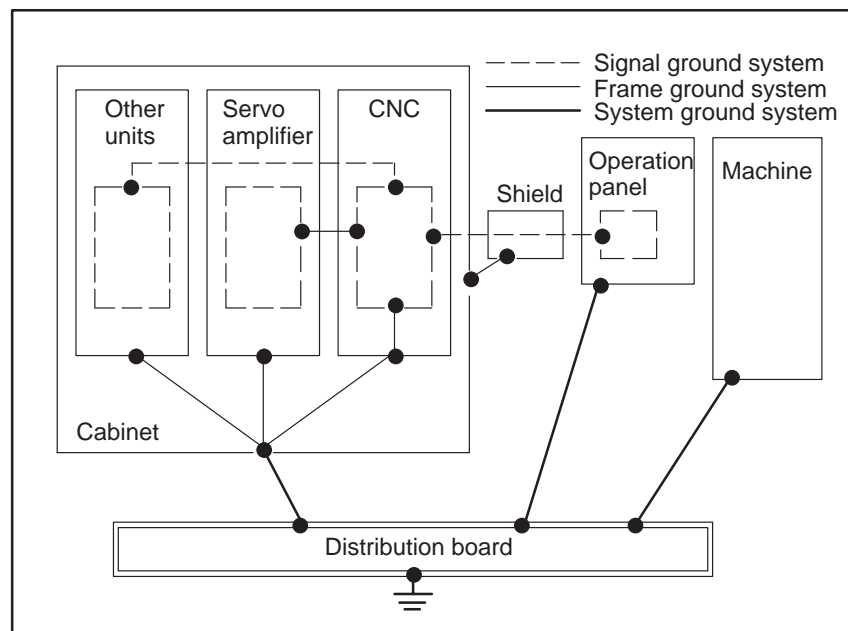

WARNING ON CONNECTING THE GROUND SYSTEMS

- The grounding resistance of the system ground shall be 100 ohms or less (class 3 grounding).
- The system ground cable must have enough cross-sectional area to safely carry the accidental current flow into the system ground when an accident such as a short circuit occurs. (Generally, it must have the cross-sectional area of the AC power cable or more.)
- Use the cable containing the AC power wire and the system ground wire so that power is supplied with the ground wire connected. See Sec. 5.3 for details when a power transformer for an export is used.

7.3.3 SVU Grounding for CE Marking (EC Machinery Directive)

To gain approval to affix the CE marking, the SVU must be grounded using the metal terminal supplied with it.

NOTE

The SVUC does not comply with European safety standards (VDE 0160). No metal terminal is, therefore, supplied with the SVUC.

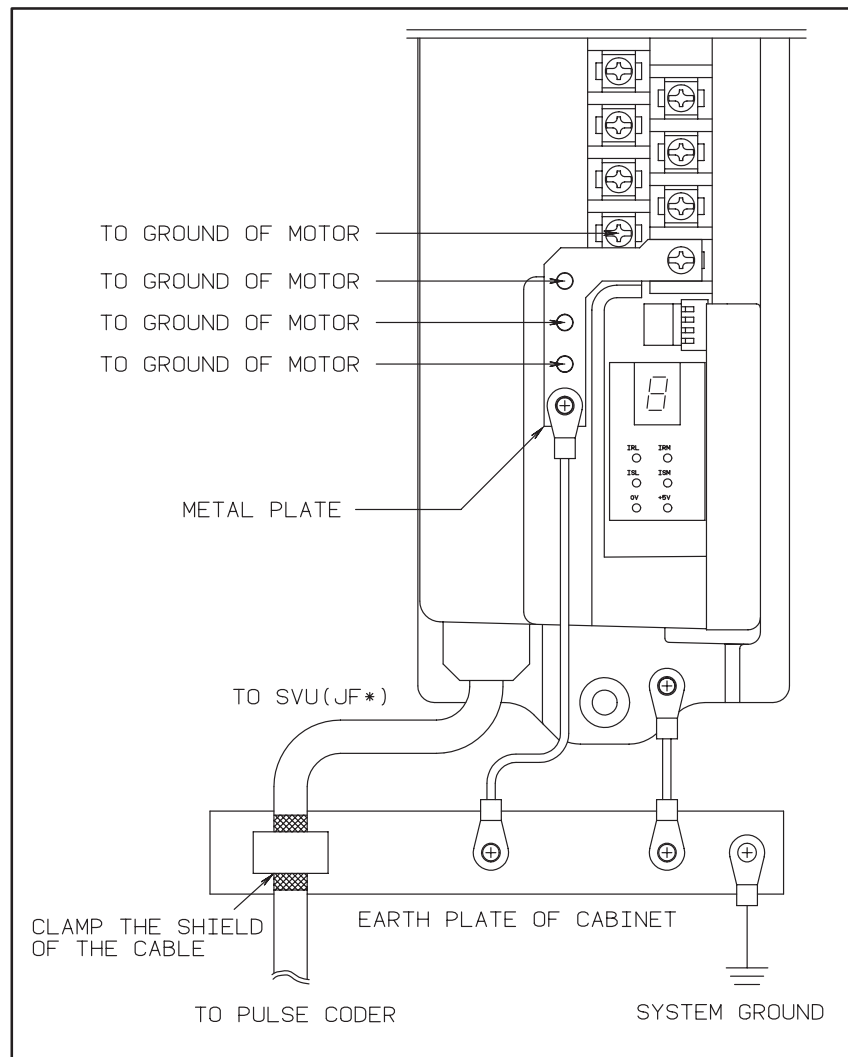

8

OUTLINE DRAWINGS AND AREA OF MAINTENANCE

8.1 OUTLINE DRAWINGS AND AREA OF MAINTENANCE

8.1.1 Servo Amplifier Unit

(1) SVU1-12, 20 / SVUC1-4, 12

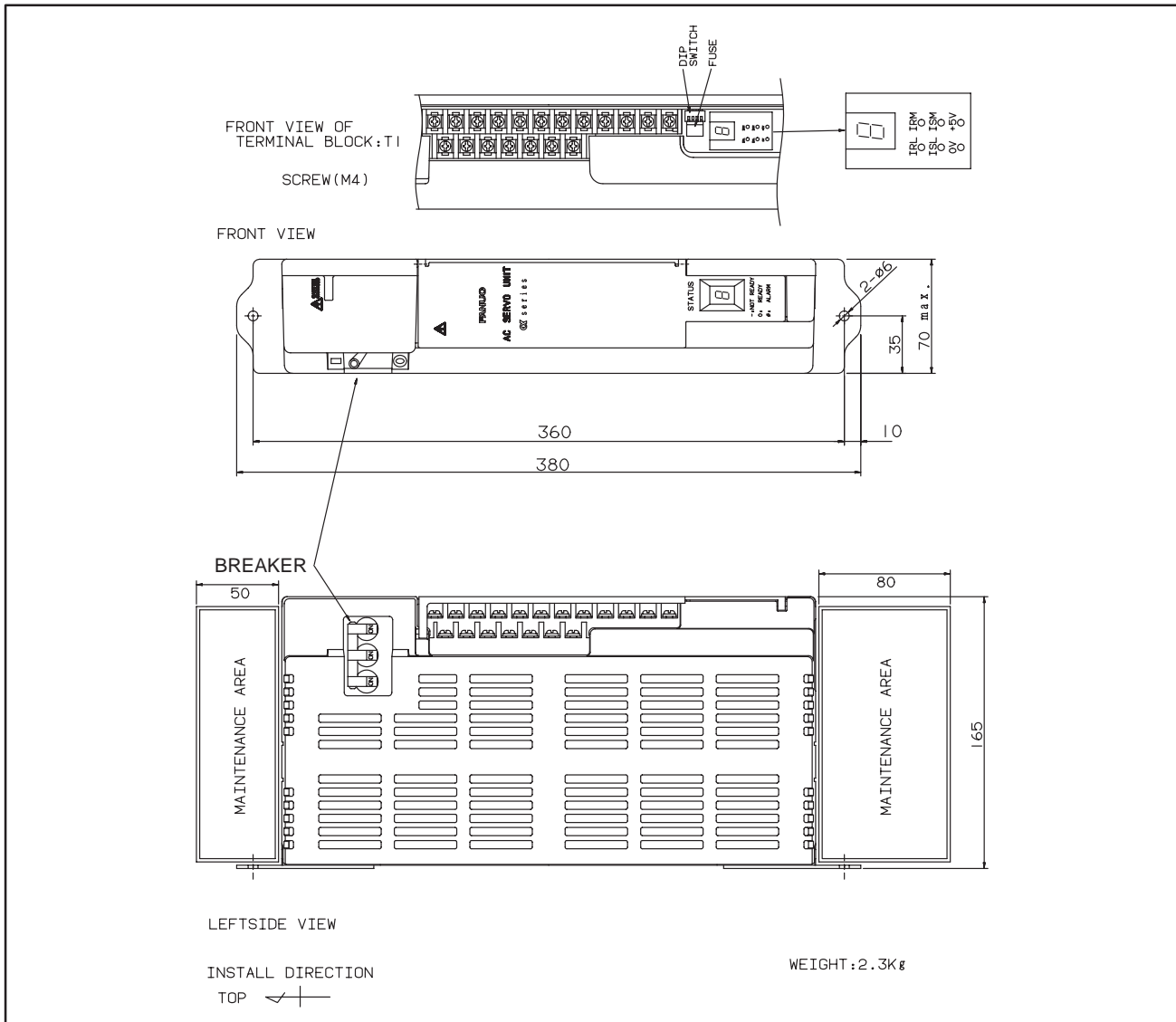

(2) SVU1-40, 80 / SVUC1-40, 80

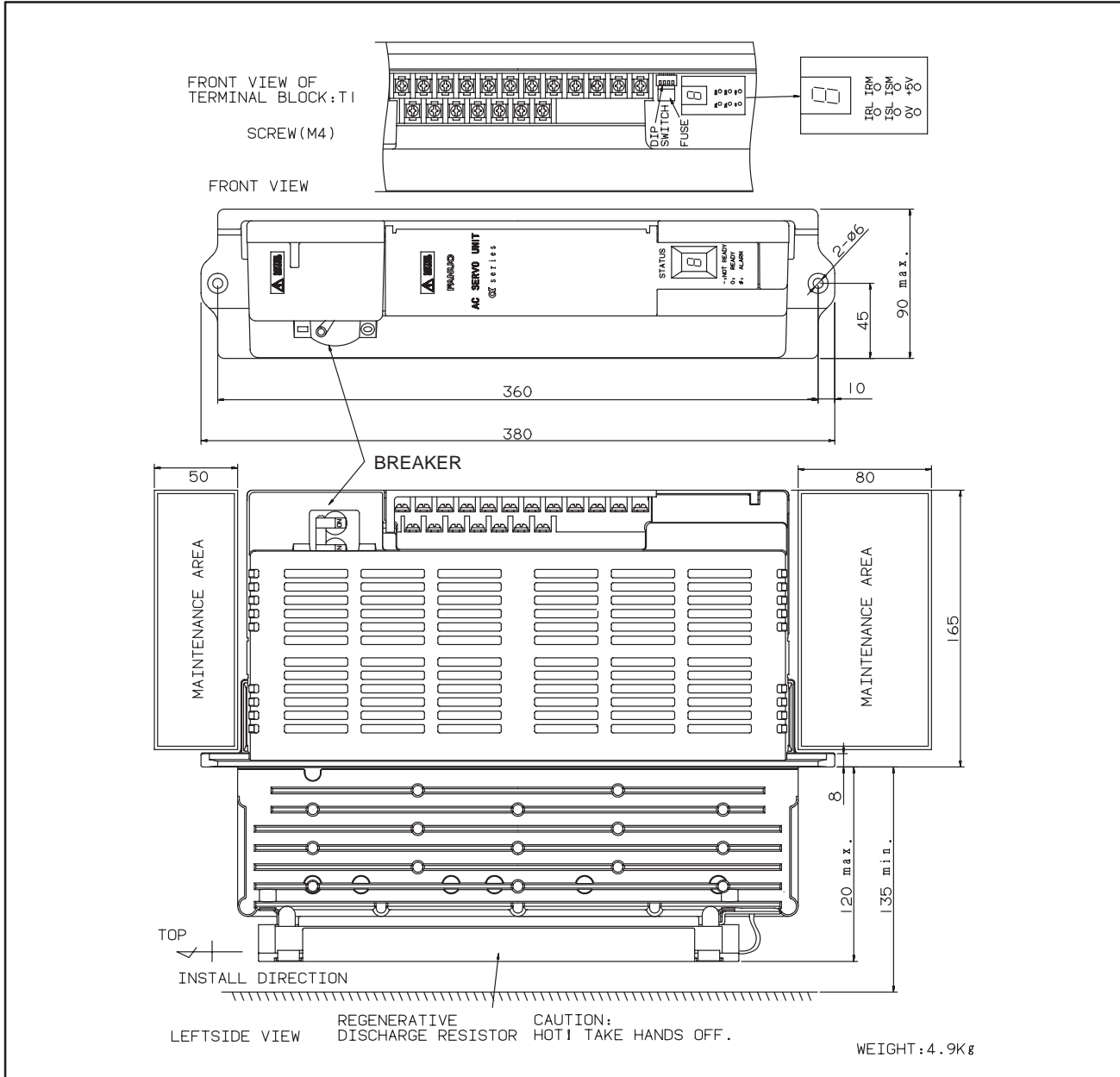

CAUTION

PARTS INSTALLATION IS NOT PERMITTED HERE
BECAUSE OF THE HEAT GENERATED BY THE
DISCHARGE RESISTOR.

(3) SVU1-130 / SVUC1-130

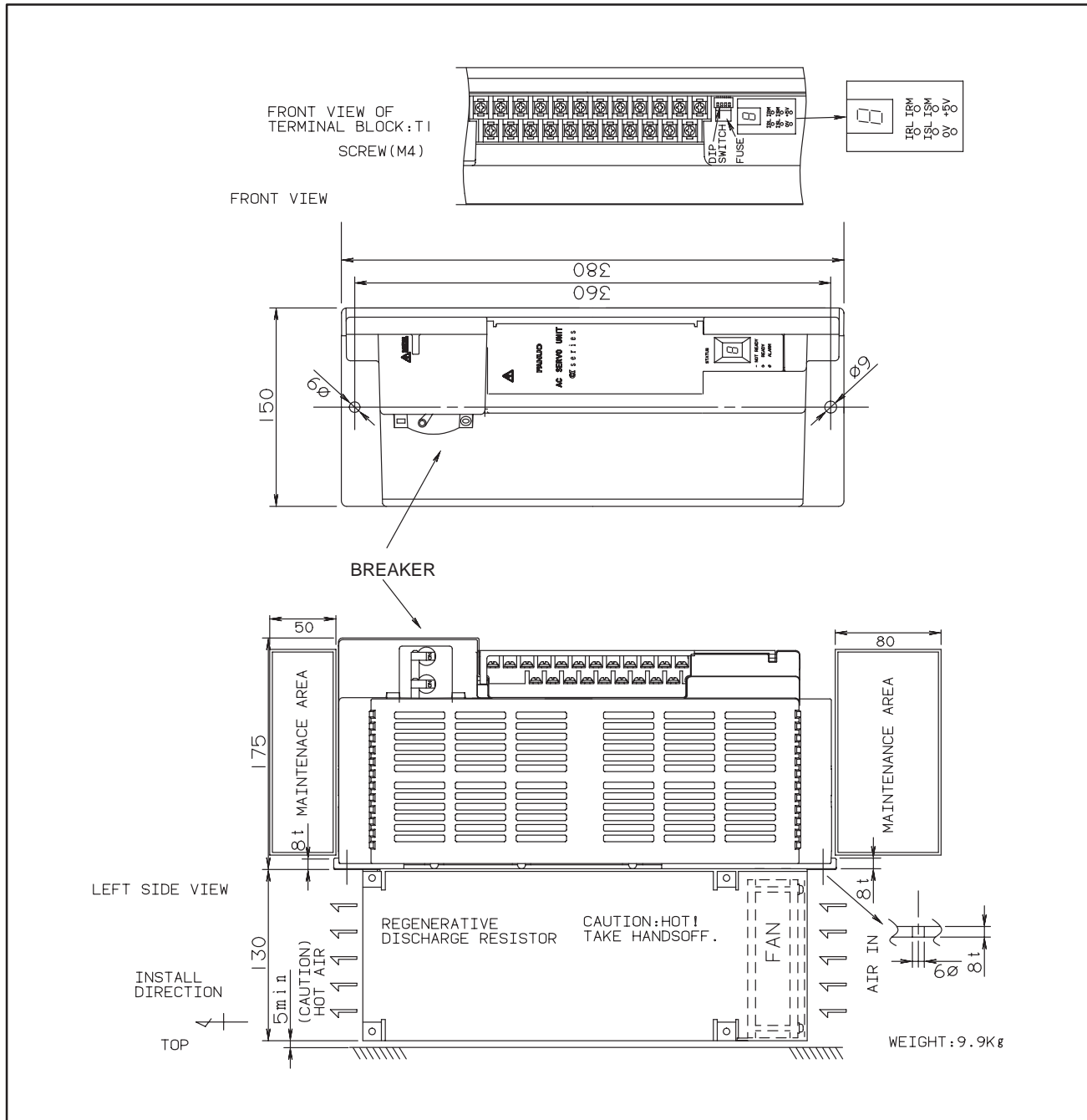

CAUTION

PARTS INSTALLATION IS NOT PERMITTED HERE BECAUSE OF THE HEAT GENERATED BY THE DISCHARGE RESISTOR.

(4) SVU2 / SVUC2

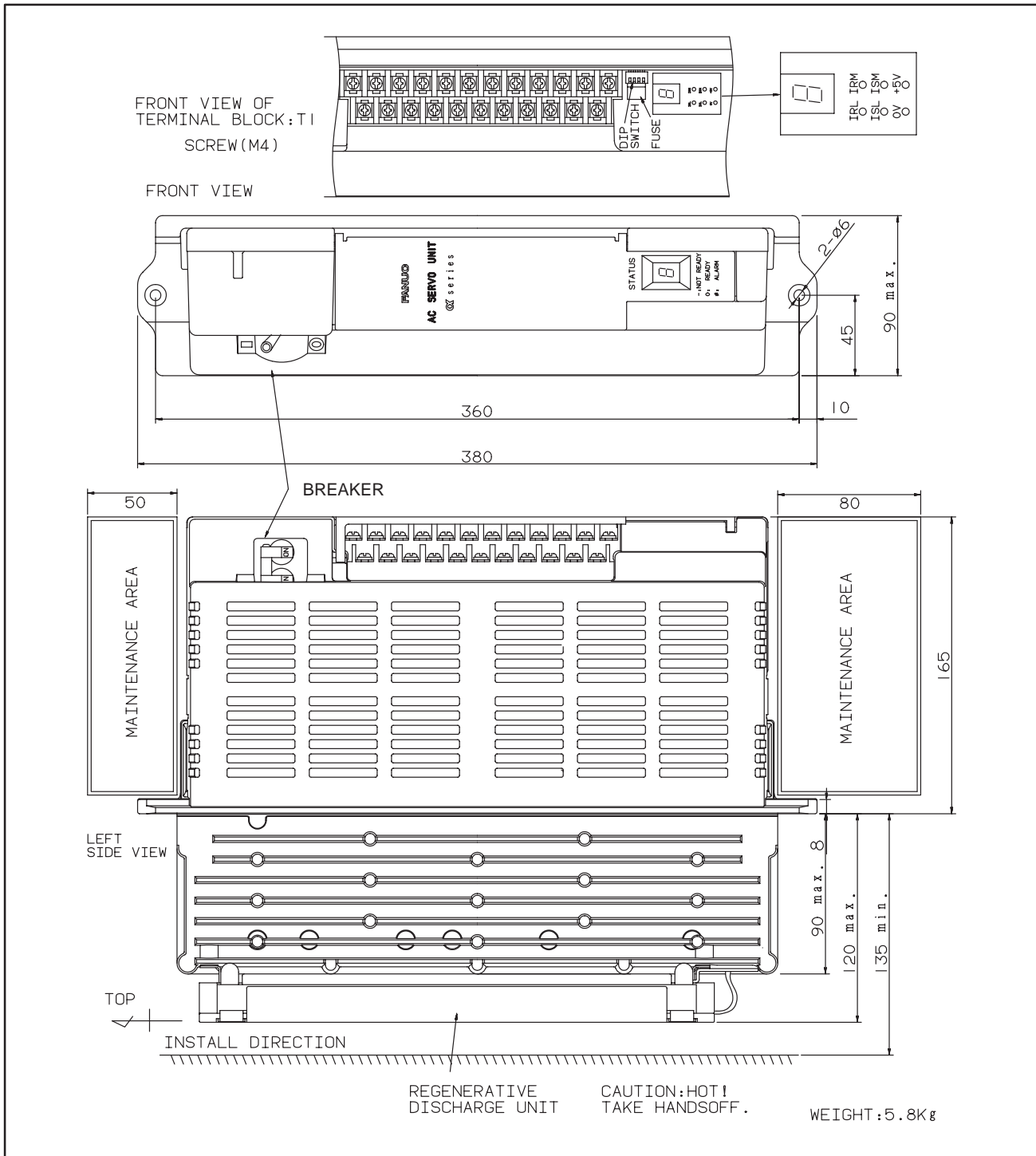

CAUTION

PARTS INSTALLATION IS NOT PERMITTED HERE
BECAUSE OF THE HEAT GENERATED BY THE
DISCHARGE RESISTOR.

8.1.2 AC Line Filter

(1) A81L-0001-0083#3C

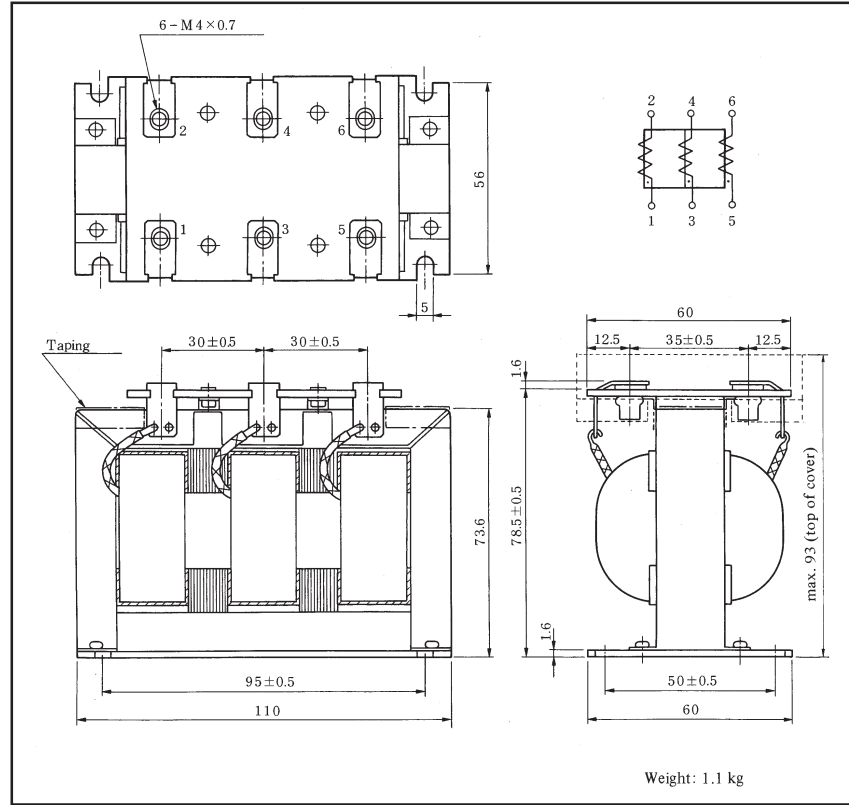

(2) A81L-0001-0101#C

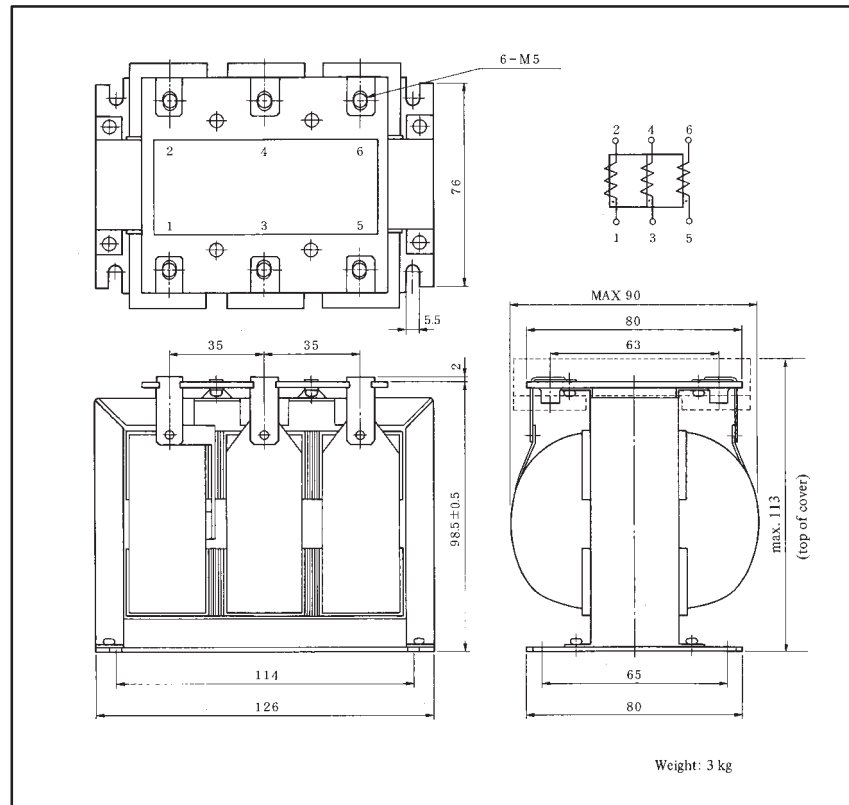

(3) A81L-0001-0102

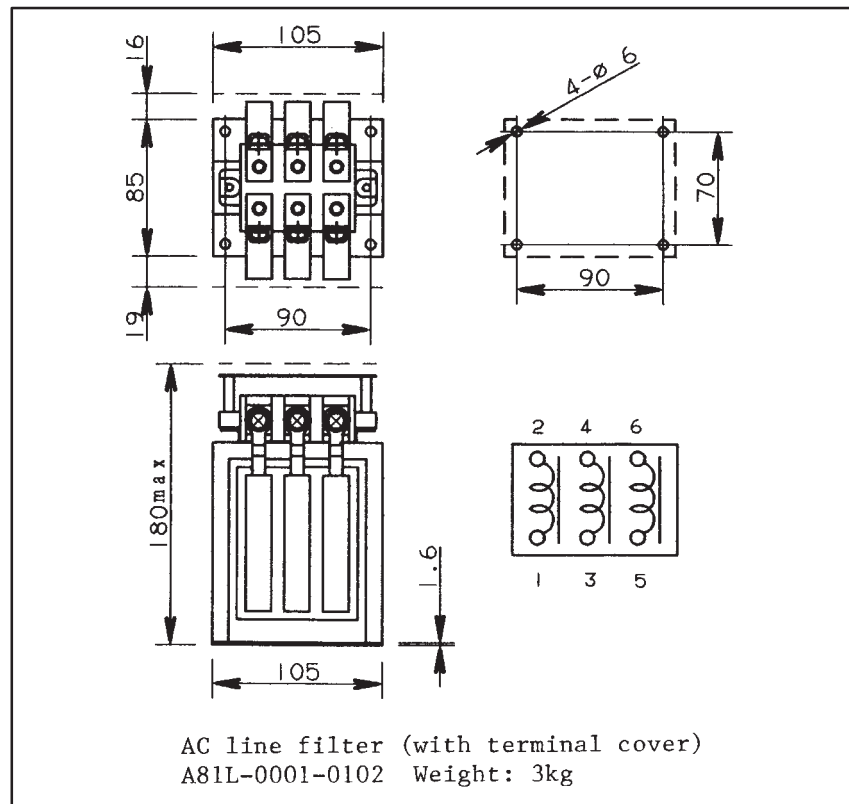

AC line filter (with terminal cover)
A81L-0001-0102 Weight: 3kg

8.1.3 Power Transformer for Export

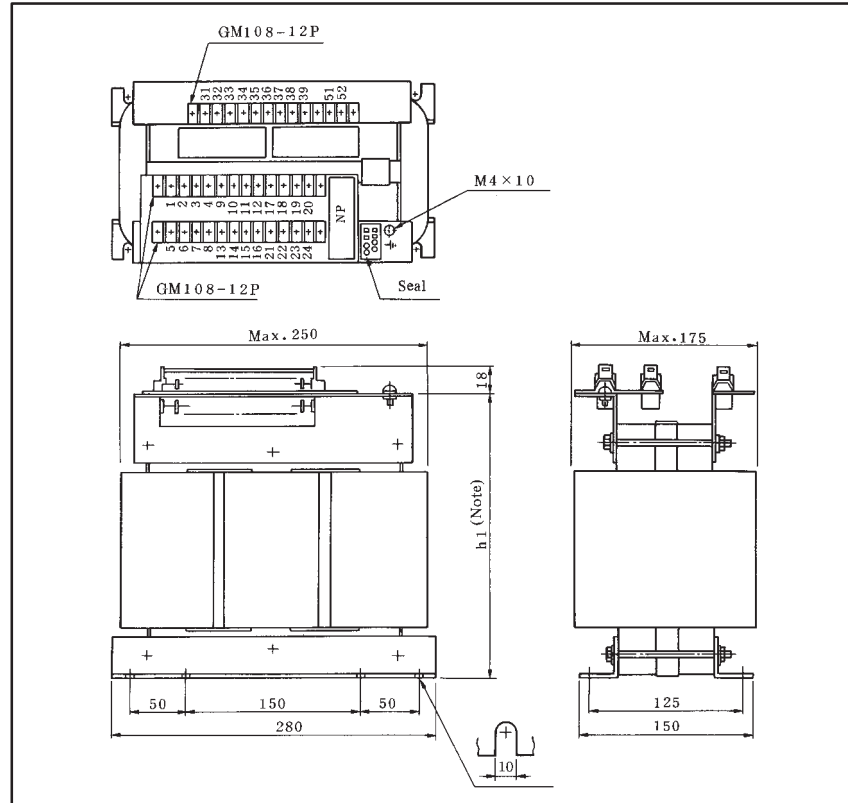

Designation	A80L-0022-0005	A80L-0024-0006	A80L-0026-0003	A80L-0028-0001
Type	SAE	SBE	SCE	SDE
Weight	21 kg	27 kg	36 kg	42 kg
h1 × (height of trans)	217cm Max.	217cm Max.	247cm Max.	247cm Max.

Connection of Power Cable and Jumper

Power voltage	Input power cable U, V, W	Jumper between terminals	Remarks
200V	U-7, V-15, W-23	8-15, 16-23, 24-7	Delta connection
220V	U-6, V-14, W-22	8-14, 16-22, 24-6	
230V	U-5, V-13, W-21	8-13, 16-21, 24-5	
240V	U-4, V-12, W-20	8-12, 16-20, 24-4	
380V	U-6, V-14, W-22	8-16, 16-24 or (8-16-24)	Star connection
415V	U-4, V-12, W-20		
460V	U-3, V-11, W-19		
480V	U-2, V-10, W-18		
550V	U-1, V-9, W-17		

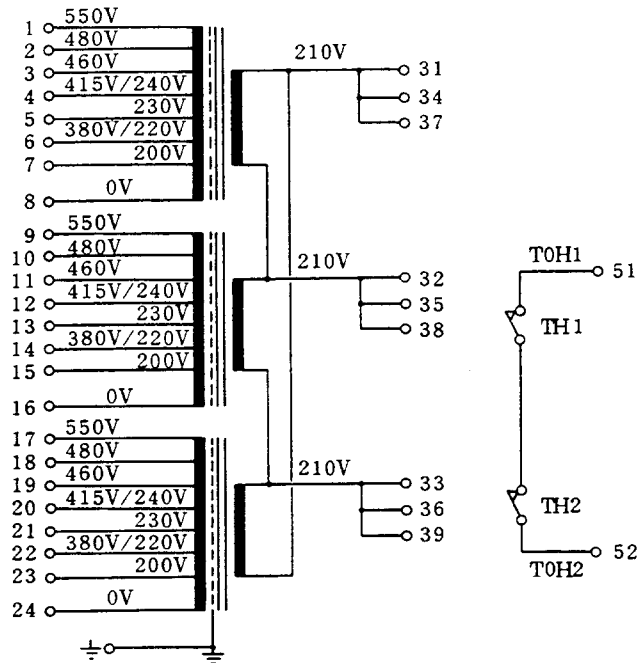

Connection Diagram

8.1.4 Separate Regenerative Discharge Unit

(1) A06B-6089-H510

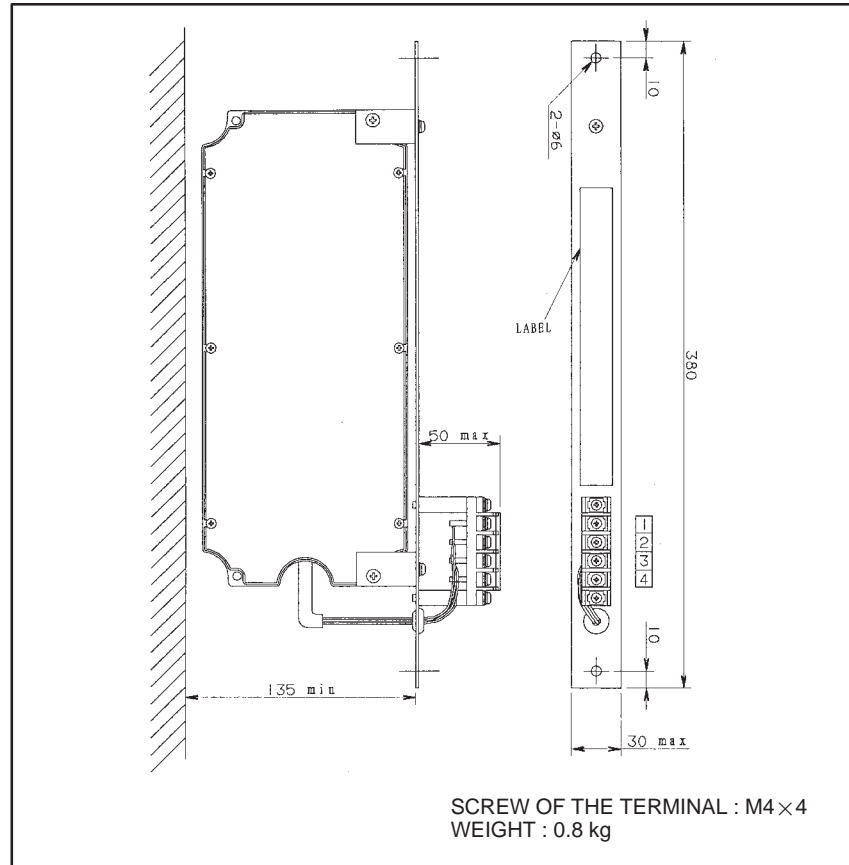

(2) A06B-6089-H500

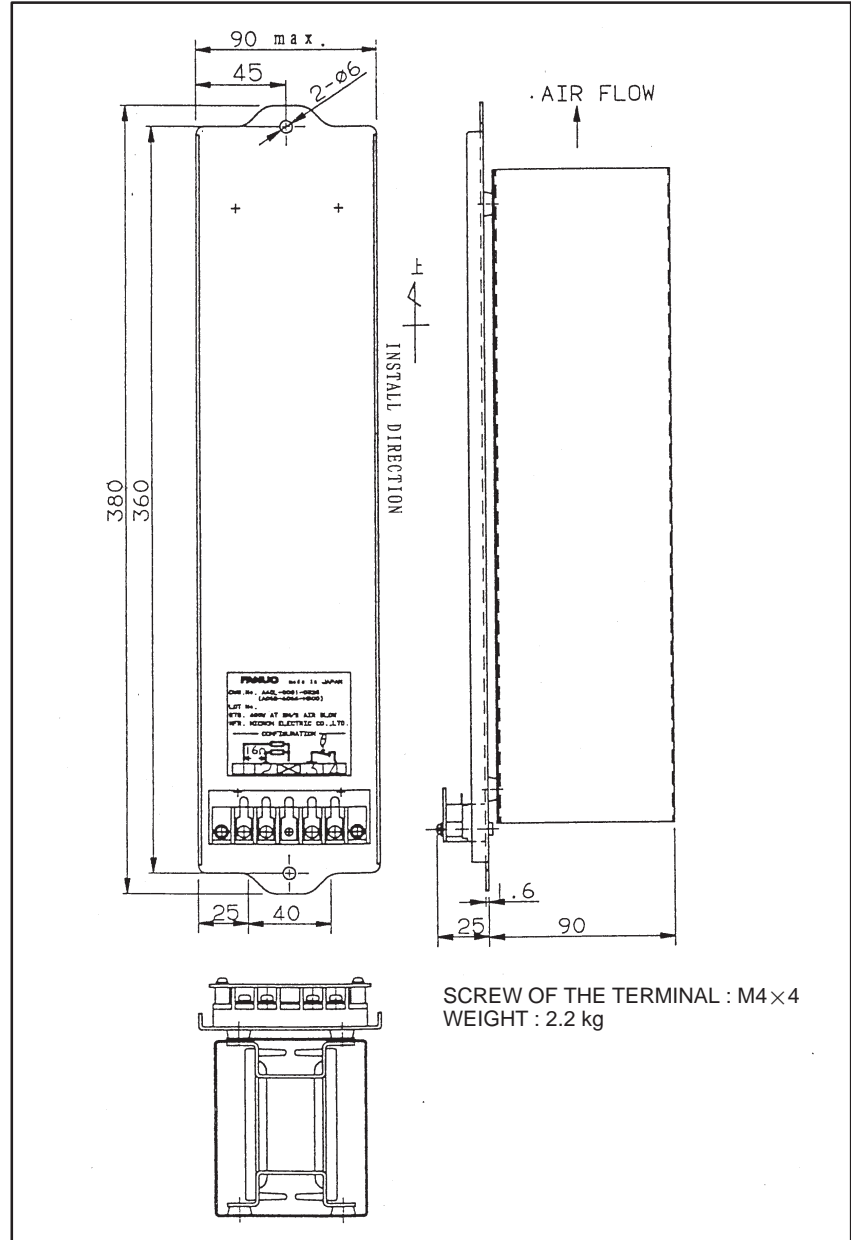

8.1.5 Battery Case

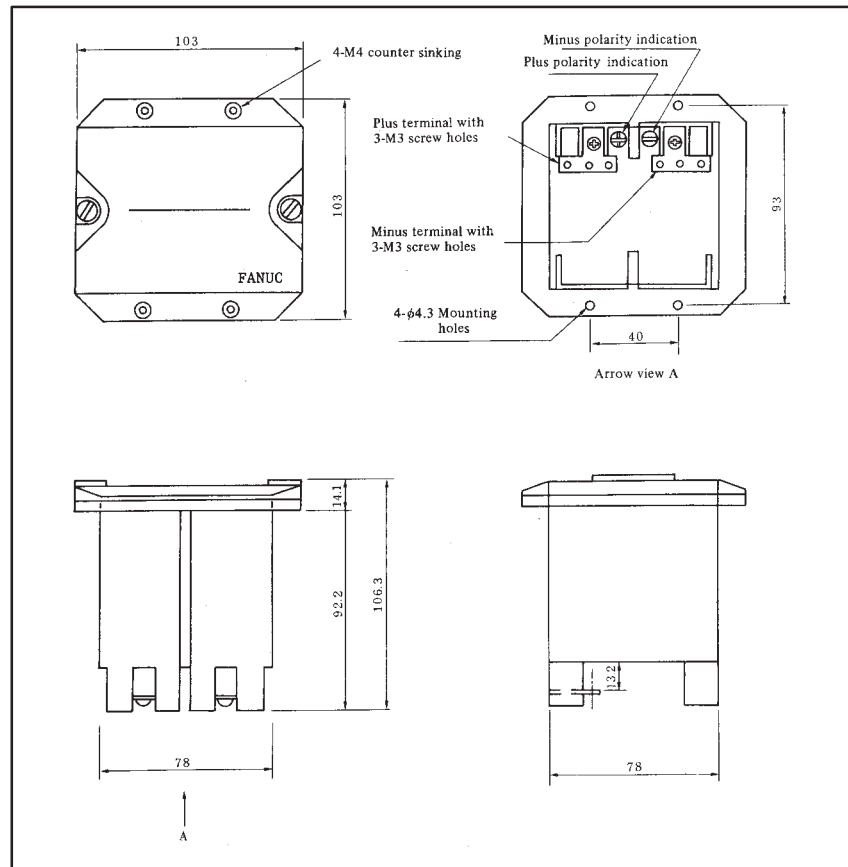

8.2 PANEL CUTOUT DRAWING

8.2.1 Servo Amplifier Unit

(1) SVU1-12, -20

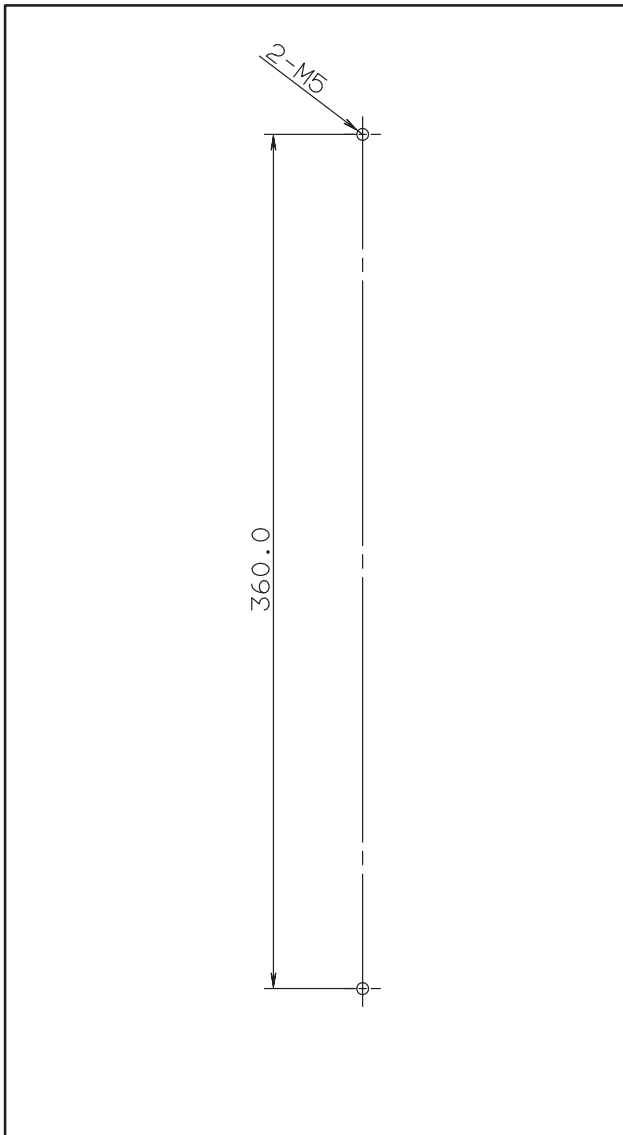

(2) SVU1-40, -80 SVU2-□/□

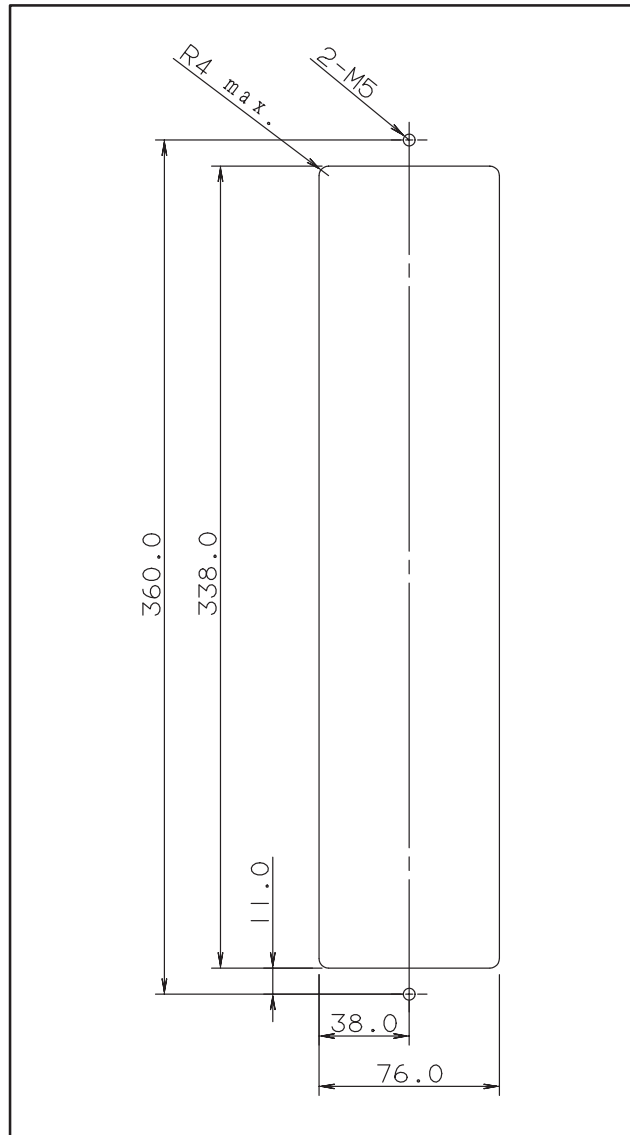

(3) SVU1-130

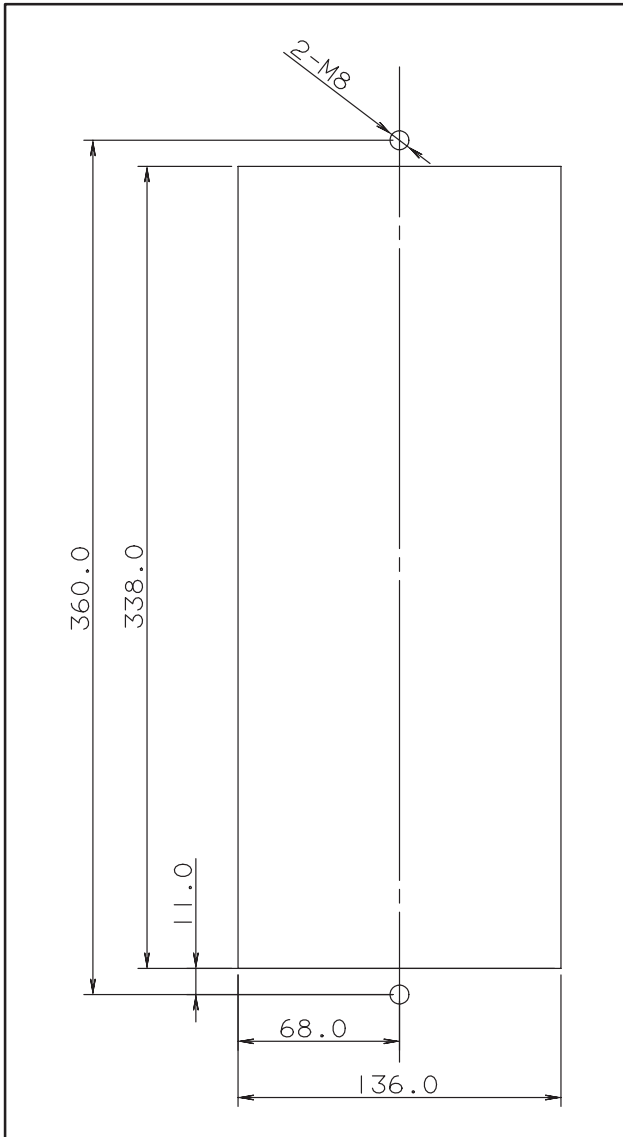

8.2.2 Separate Regenerative Discharge Unit

(1) A06B-6089-H510

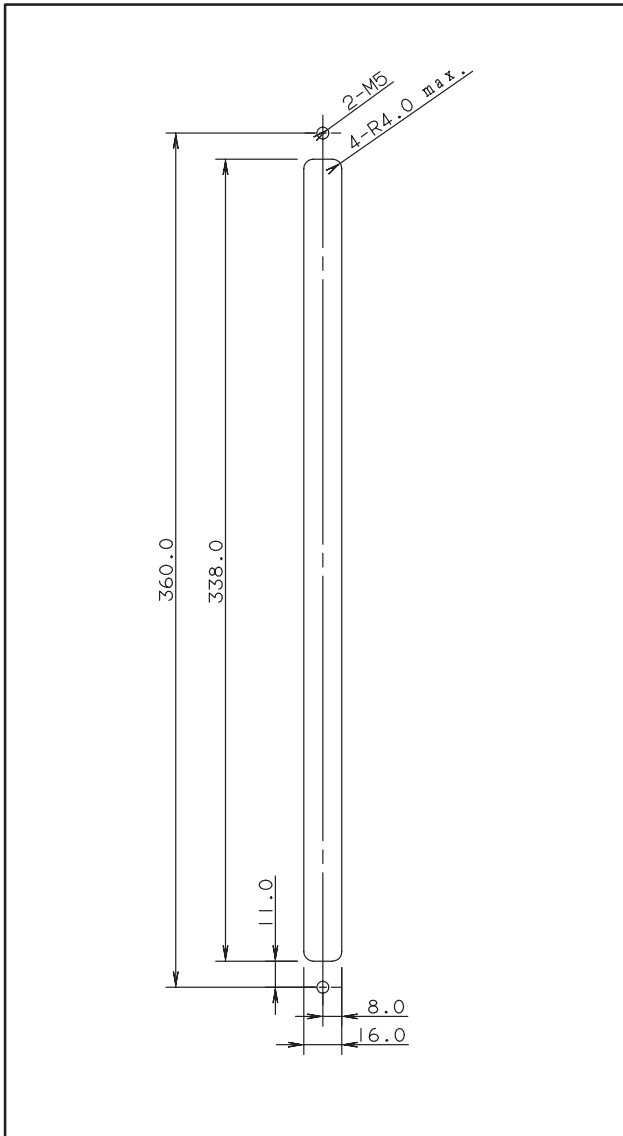

(2) A06B-6089-H500

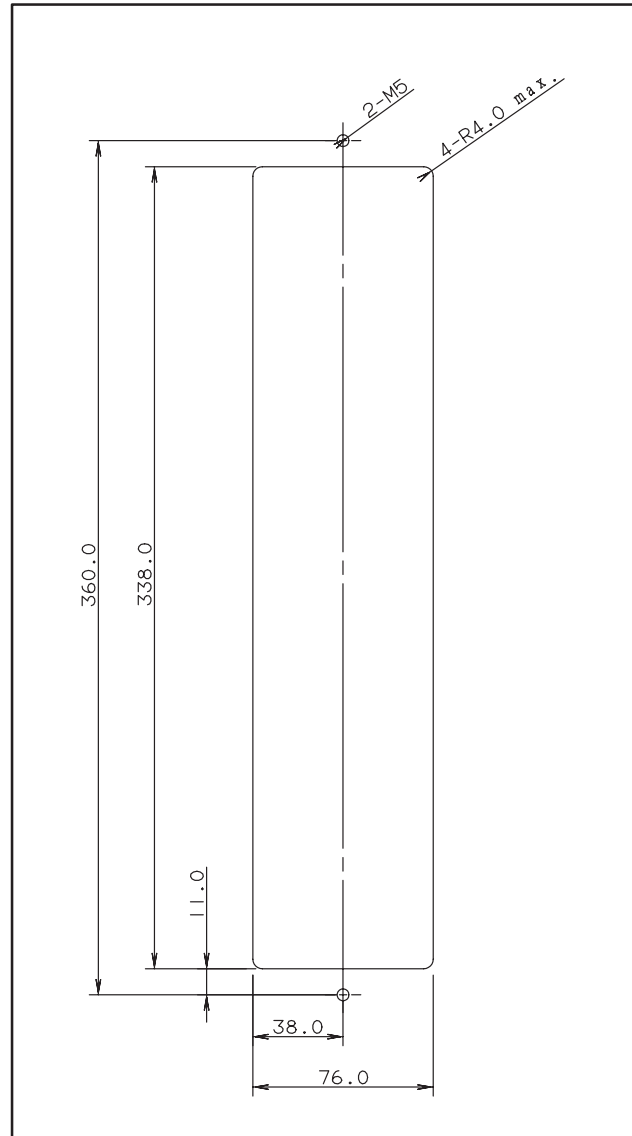

CAUTION

ATTACH PACKINGS (ACRYLONITRILE-BUTADIENE RUBBER OR SOFT NBR) TO PREVENT THE INGRESS OF OIL AND DUST.

(3) A06B-6089-H711 to H714

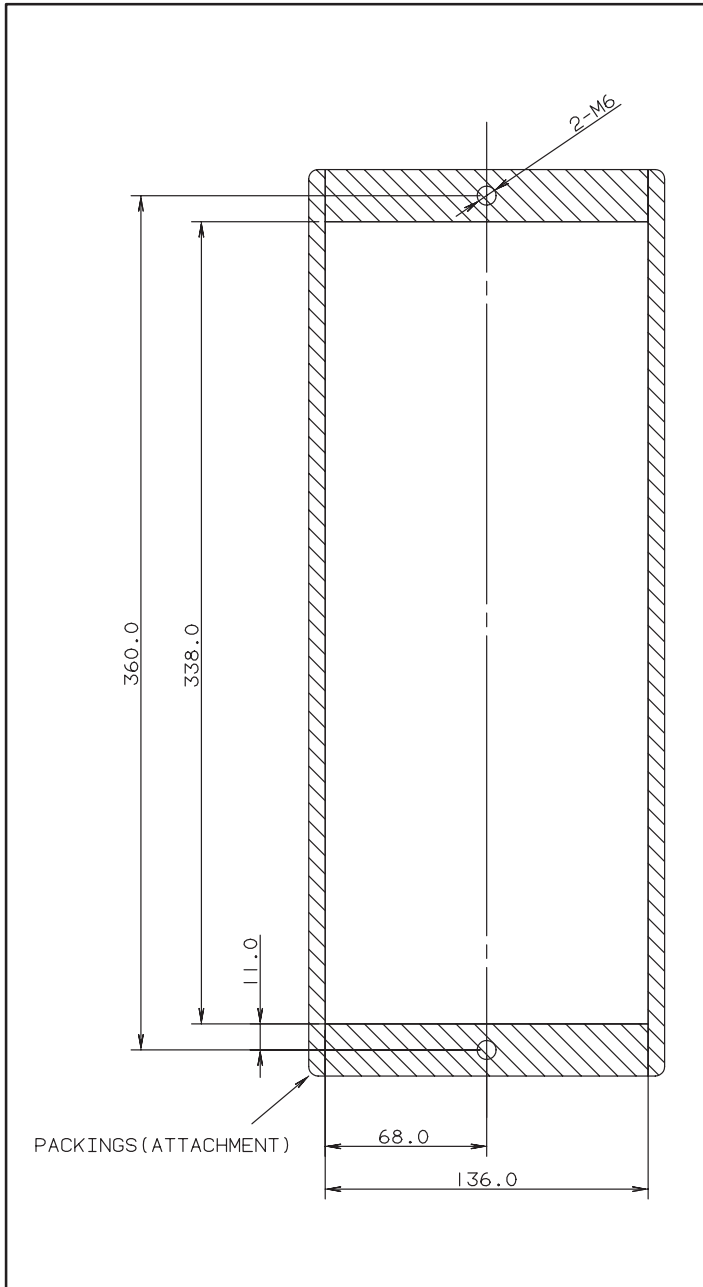

CAUTION

ATTACH PACKINGS (ACRYLONITRILE-BUTADIENE RUBBER OR SOFT NBR) TO PREVENT THE INGRESS OF OIL AND DUST.

9

CONNECTION

9.1 OVERVIEW

9.1.1 Interface with the NC

This servo amplifier unit has two types of NC interface. Cable connection varies with the interface type used. Before starting to connect, check the model of the NC unit and interface type.

Interface type	NC
TYPE A	Series 0–C, Series 15–A, Series 15–B, Series 16–A, Series 16–B, Series 18–A, Series 21–TA, Power Mate–D, Power Mate–F
TYPE B	Series 20–A, Series 21–TB, Series 21–GA, Series 16–B, Series 18–B, Power Mate–H

CAUTION

The Series 16–B can have both types of interface. Check the interface type with the arranged NC.

9.1.2 Safety Standards

SVU: This unit has been designed to comply with VDE0160. A machine that is configured using this unit would easily be able to gain approval to display the CE marking (machinery directive). A requirement for obtaining approval is an external MCC which trips in the event of an emergency stop.

Sample connections without external MCC: 9.2.1 (1), (2)

Sample connections with external MCC: 9.2.1 (3), (4)

SVUC: This unit does not comply with VDE0160. A machine configured using the unit will not be able to gain approval to display the CE marking.

Sample general connections: 9.2.2 (1), (2)

9.2 BASIC CONNECTION

9.2.1 Connection Example for SVU

- (1) Sample connection with TYPE A interface but without external MCC
 - 1-AXIS (A06B-6089-H101 to H106)
 - 2-AXIS (A06B-6089-H201 to H210)

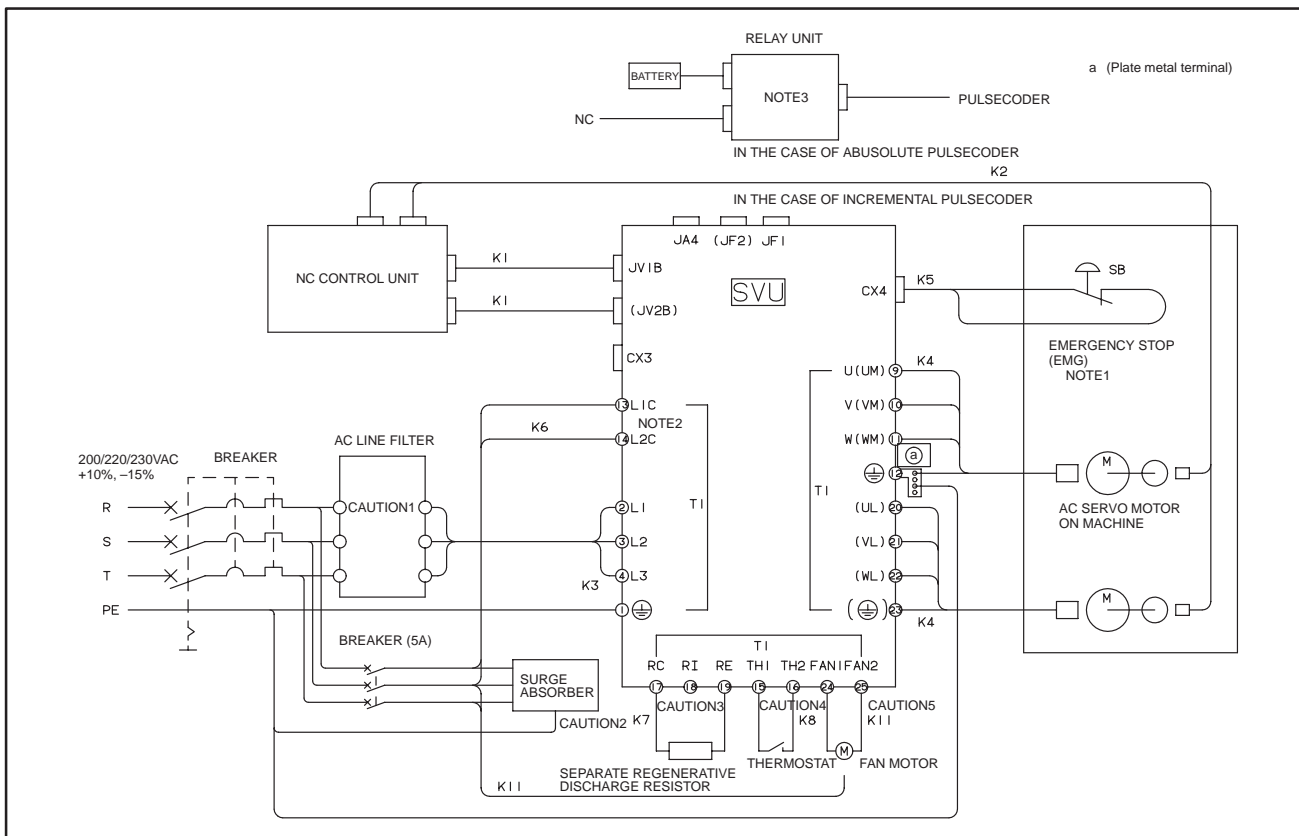

- (2) Sample connection with TYPE B interface but without external MCC
 1-AXIS (A06B-6089-H101 to H106)
 2-AXIS (A06B-6089-H201 to H210)

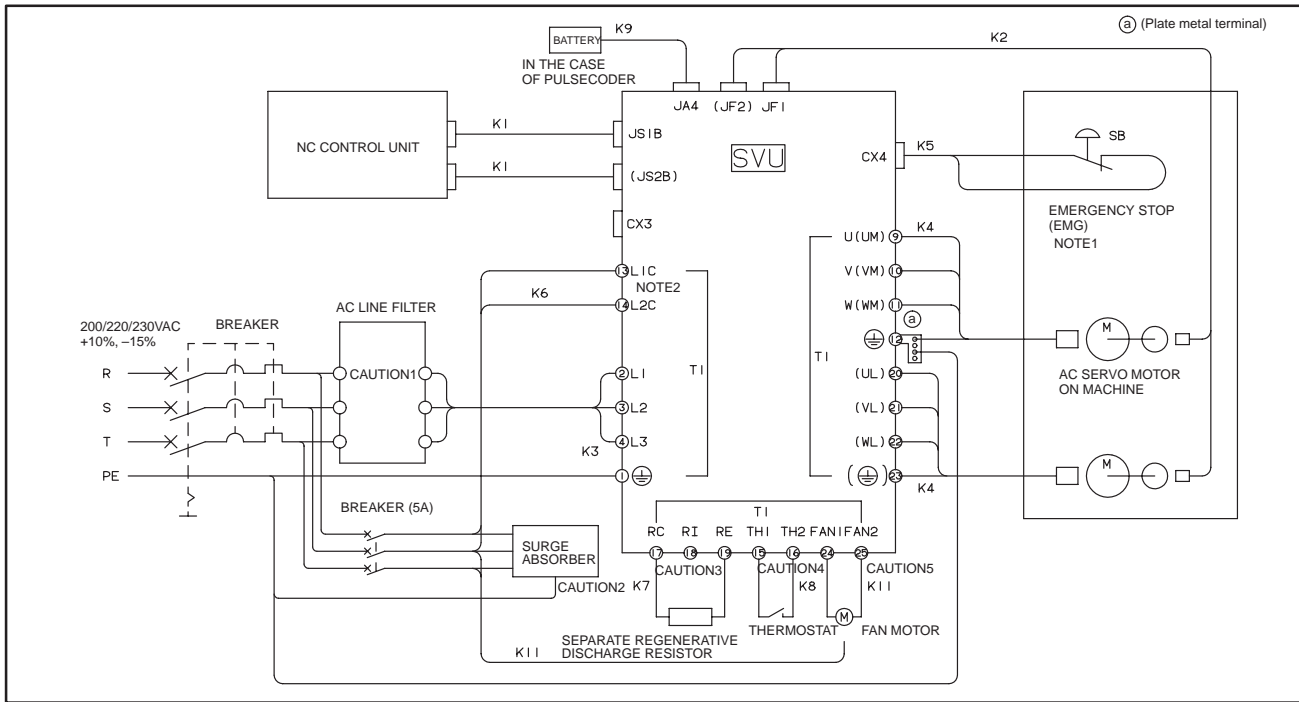

- (3) Sample connection with TYPE A interface and external MCC
 1-AXIS (A06B-6089-H101 to H106)
 2-AXIS (A06B-6089-H201 to H210)

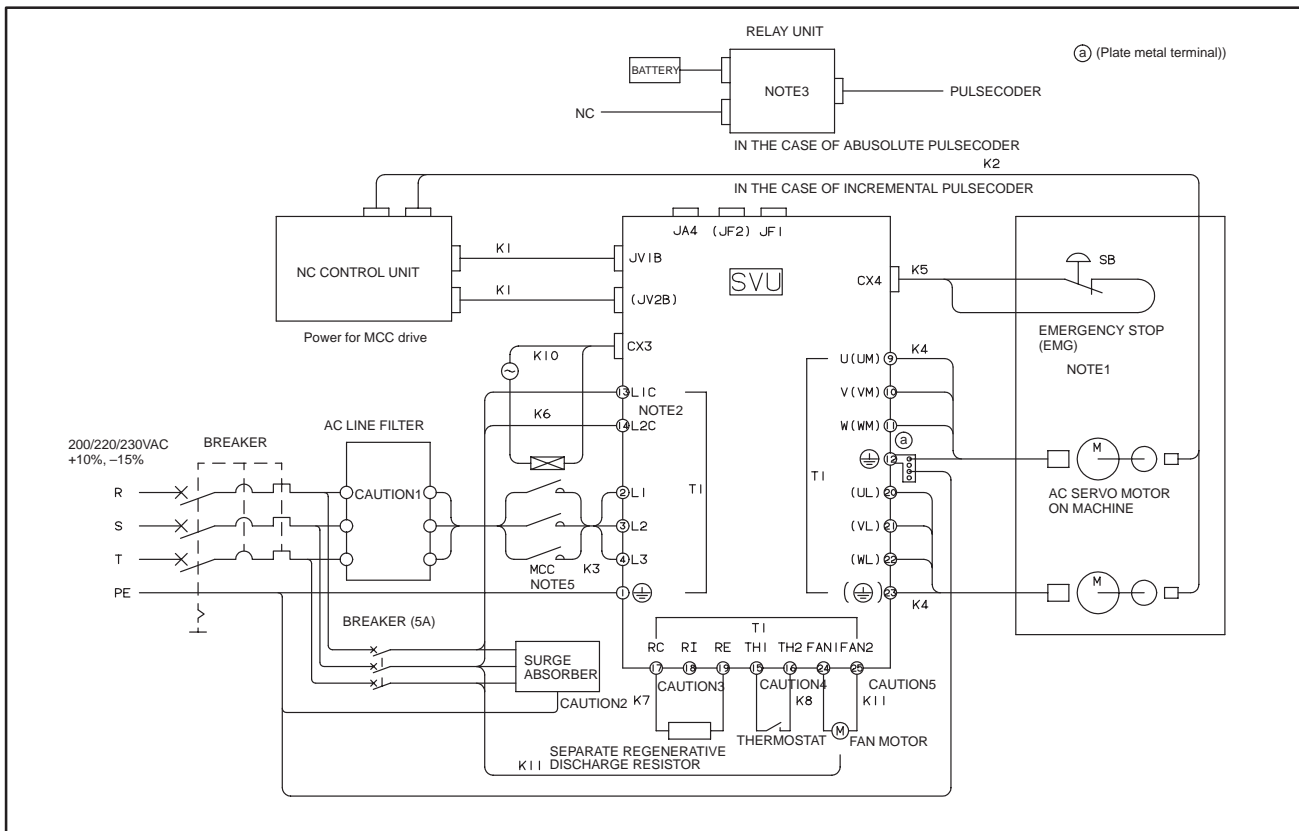

- (4) Sample connection with TYPE B interface and external MCC
- 1-AXIS (A06B-6089-H101 to H106)
- 2-AXIS (A06B-6089-H201 to H210)

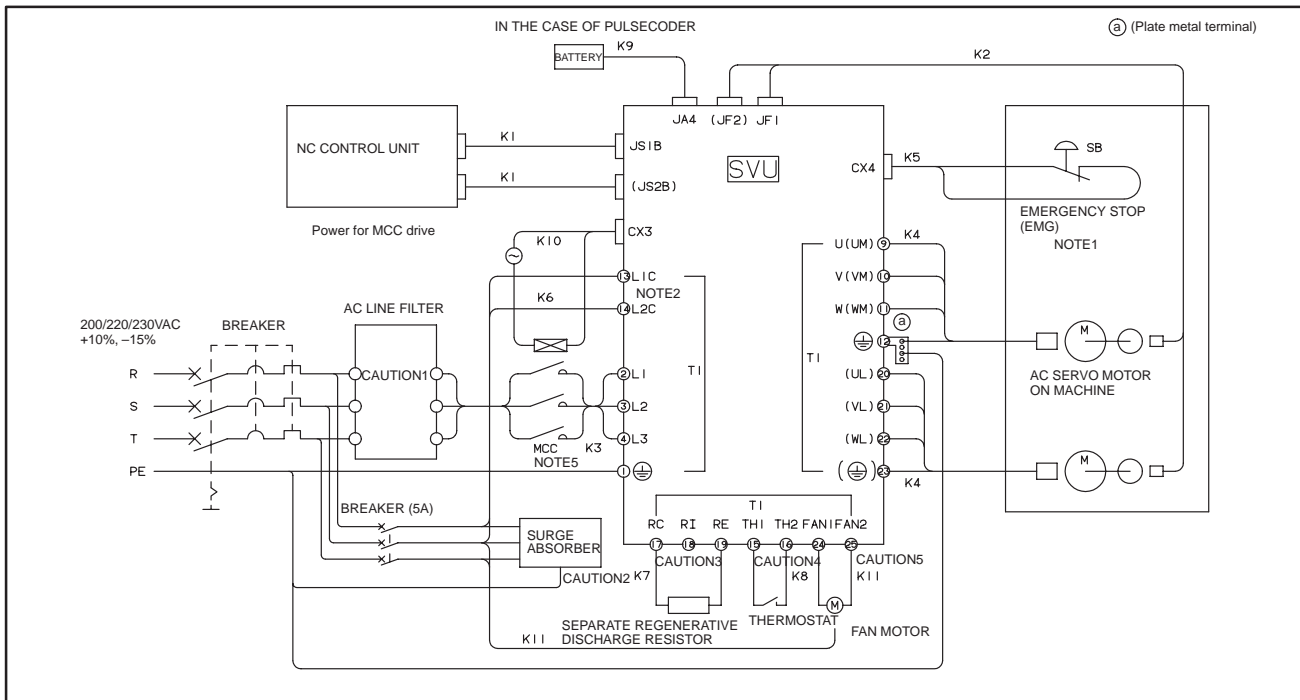

CAUTION

- 1 Be sure to use an AC line filter to reduce effect of harmonic noise to the power supply. Two or more SVUs can be connected to one AC line filter if its power supply capacity is not exceeded.
- 2 SVU does not contain a surge absorber. One should be installed externally.
- 3 RC and RI were connected with each other through a jumper bar at the factory. If a separate regenerative discharge unit is to be used, remove the jumper bar.
- 4 TH1 and TH2 were connected with each other through a jumper bar at the factory. Remove the jumper bar, and connect them to the separate regenerative discharge unit and power transformer thermostat.
- 5 Only the A06B-6089-H106 has FAN1 and FAN2. Connect them to the fan motor of the separate regenerative discharge unit. If a separate regenerative discharge unit (other than the A06B-6089-H106) with a built-in fan motor is to be used, connect the fan motor to the circuit breaker (5A).

NOTE

- 1 Unlike the C series amplifiers, SVU does not require 100 VAC for an emergency stop.
- 2 L1C and L1 were connected with each other through a jumper bar at the factory, and so were L2C and L2. Remove these jumper bars before connecting a power supply.
- 3 Some NC units do not require a relay unit. For details, refer to the appropriate NC connection manual.
- 4 An MCC that complies with European standards should be selected. Details of the use of the MCC should be determined by the machine tool builder.
- 5 The SVU connectors and terminal block indicated in parentheses, "()", correspond to 2-axes amplifier.

9.2.2 Connection Example for SVUC

- (1) Sample connection with the TYPE A interface
1-Axis (A06B-6090-H002 to H008)
2-Axis (A06B-6090-H222 to H266)

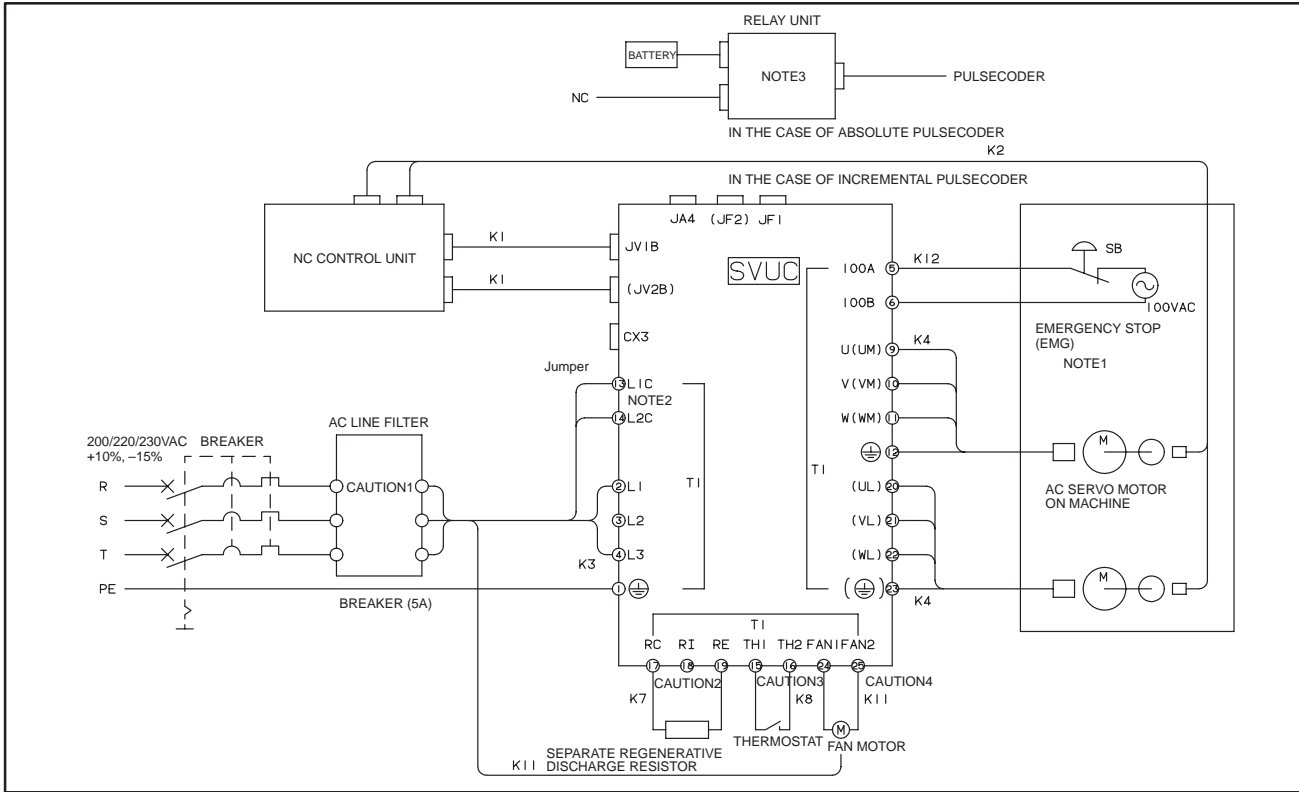

- (2) Sample connection with the TYPE B interface
1-Axis (A06B-6090-H002 to H008)
2-Axis (A06B-6090-H222 to H266)

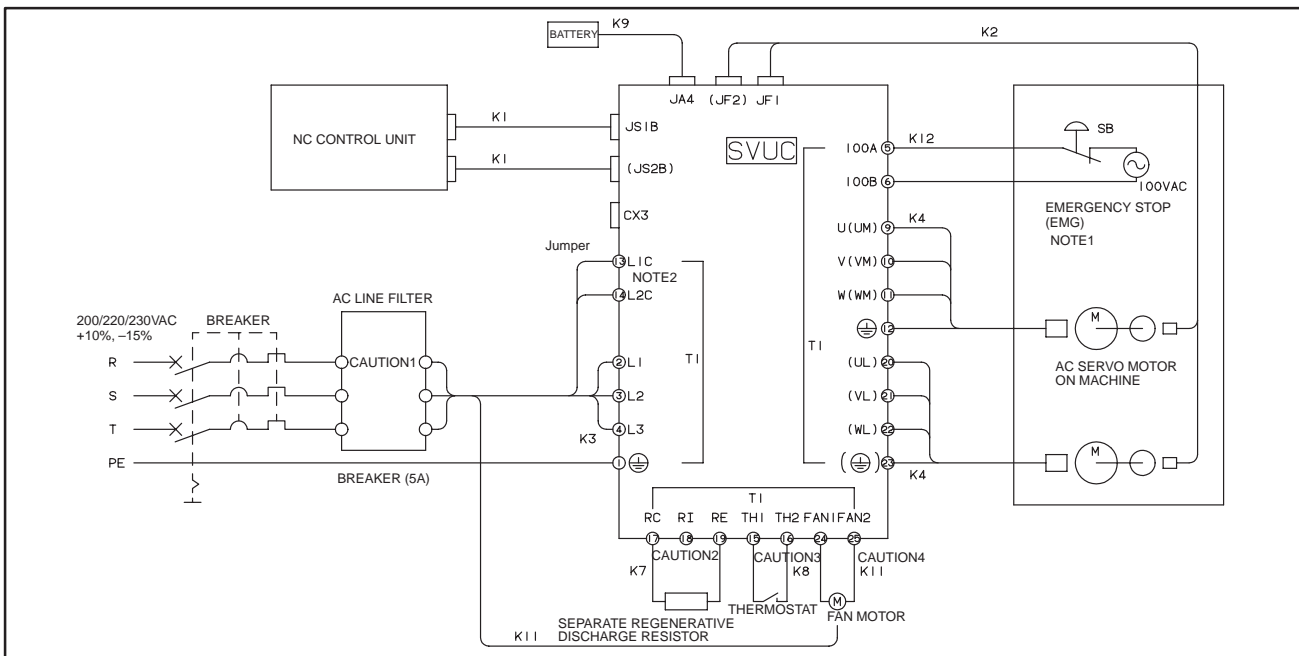

CAUTION

- 1 Be sure to use an AC line filter to reduce effect of harmonic noise to the power supply. Two or more SVUCs can be connected to one AC line filter if its power supply capacity is not exceeded.
- 2 RC and RI were connected with each other through a jumper bar at the factory. If a separate regenerative discharge unit is to be used, remove the jumper bar.
- 3 TH1 and TH2 were connected with each other through a jumper bar at the factory. Remove the jumper bar, and connect them to the separate regenerative discharge unit and power transformer thermostat.
- 4 Only the A06B-6090-H008 has FAN1 and FAN2. Connect them to the fan motor of the separate regenerative discharge unit.

NOTE

- 1 The unit should use 100 VAC for emergency stop, in the same way as the C series amplifier.
- 2 L1C and L1 were connected with each other through a jumper bar at the factory, and so were L2C and L2.
- 3 Some NC units do not require a relay unit. For details, refer to the appropriate NC connection manual.
- 4 The SVUC connectors and terminal block indicated in parentheses, "()", correspond to 2-axes amplifier.

9.2.3 Connector and Terminal (T1)

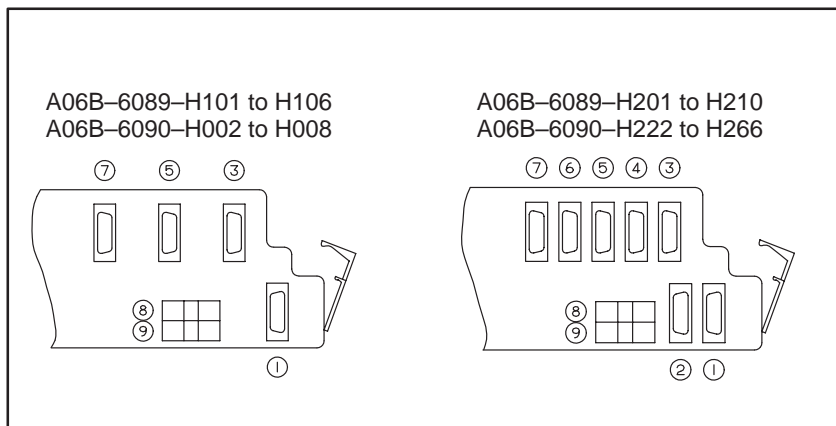

(1) Connector location

	NAME	INDICATION	REMARK
①	CONNECTOR FOR NC INTERFACE L-AXIS	JV1B	TYPE A INTERFACE
②	CONNECTOR FOR NC INTERFACE M-AXIS	JV2B	TYPE A INTERFACE
③	CONNECTOR FOR NC INTERFACE L-AXIS	JS1B	TYPE B INTERFACE
④	CONNECTOR FOR NC INTERFACE M-AXIS	JS2B	TYPE B INTERFACE
⑤	CONNECTOR FOR PULSE CODER L-AXIS	JF1	TYPE B INTERFACE
⑥	CONNECTOR FOR PULSE CODER M-AXIS	JF2	TYPE B INTERFACE
⑦	CONNECTOR FOR POWER SUPPLY OF ABS PULSE CODER	JA4	TYPE B INTERFACE
⑧	CONNECTOR FOR MAIN POWER SUPPLY (Y key)	CX3	1 pin 3 pin
⑨	CONNECTOR FOR ESP SIGNAL (X key)	CX4	2 pin ; ESP (at open) 3 pin ; 24V

CAUTION

- 1 The connector names of the α series amplifier are the same as those of the NC, but are different from those of the C series amplifier. When replacing the C series amplifier with the SVUC, therefore, note that JV1B and JV2B of the SVUC correspond to CN1(L) and CN1M of the C series amplifier.
- 2 The CX4 connector ⑨ for the ESP signal is used only on the SVU.

(2) Terminal board (T1)

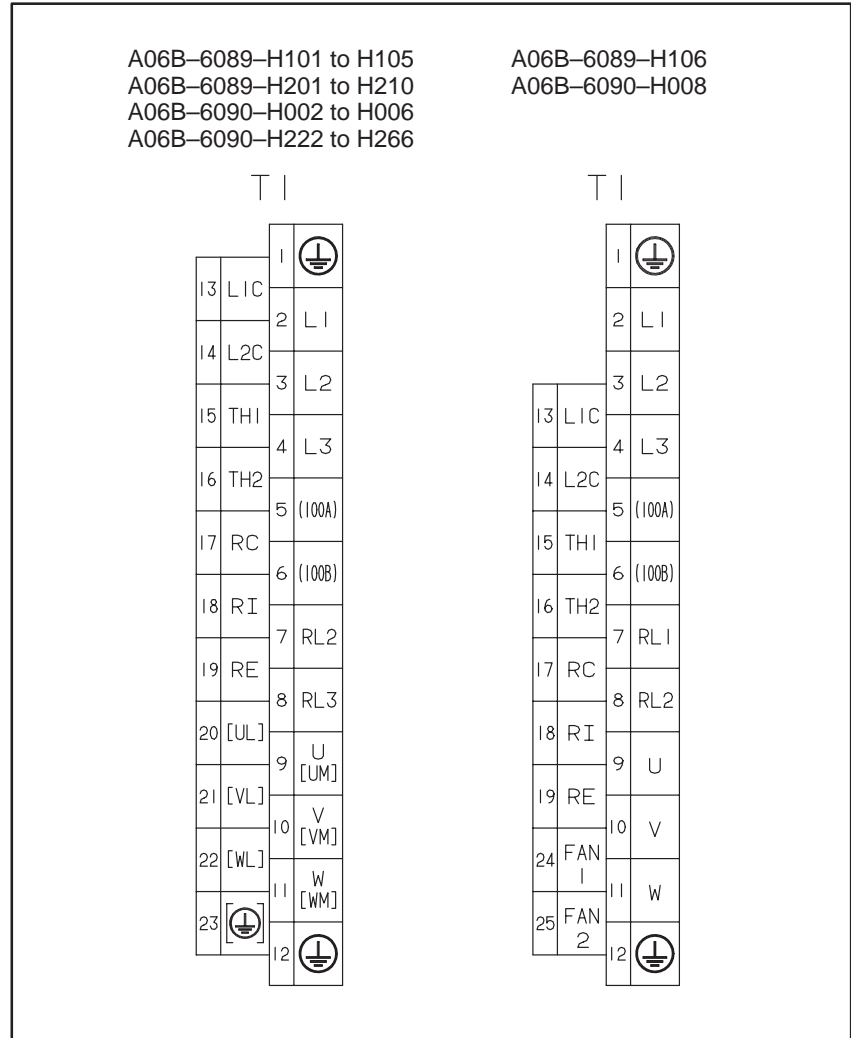

NOTE

5 and 6 on the terminal board T1 are not used with SVU.

9.3 DETAILED CONNECTION

9.3.1 Detailed Connection of Cable K1

(1) For connection to Series 16-A/B, Series 18-A, Series 15-B, Series 21-TA, Power Mate-D, or Power Mate-F (TYPE A I/F)

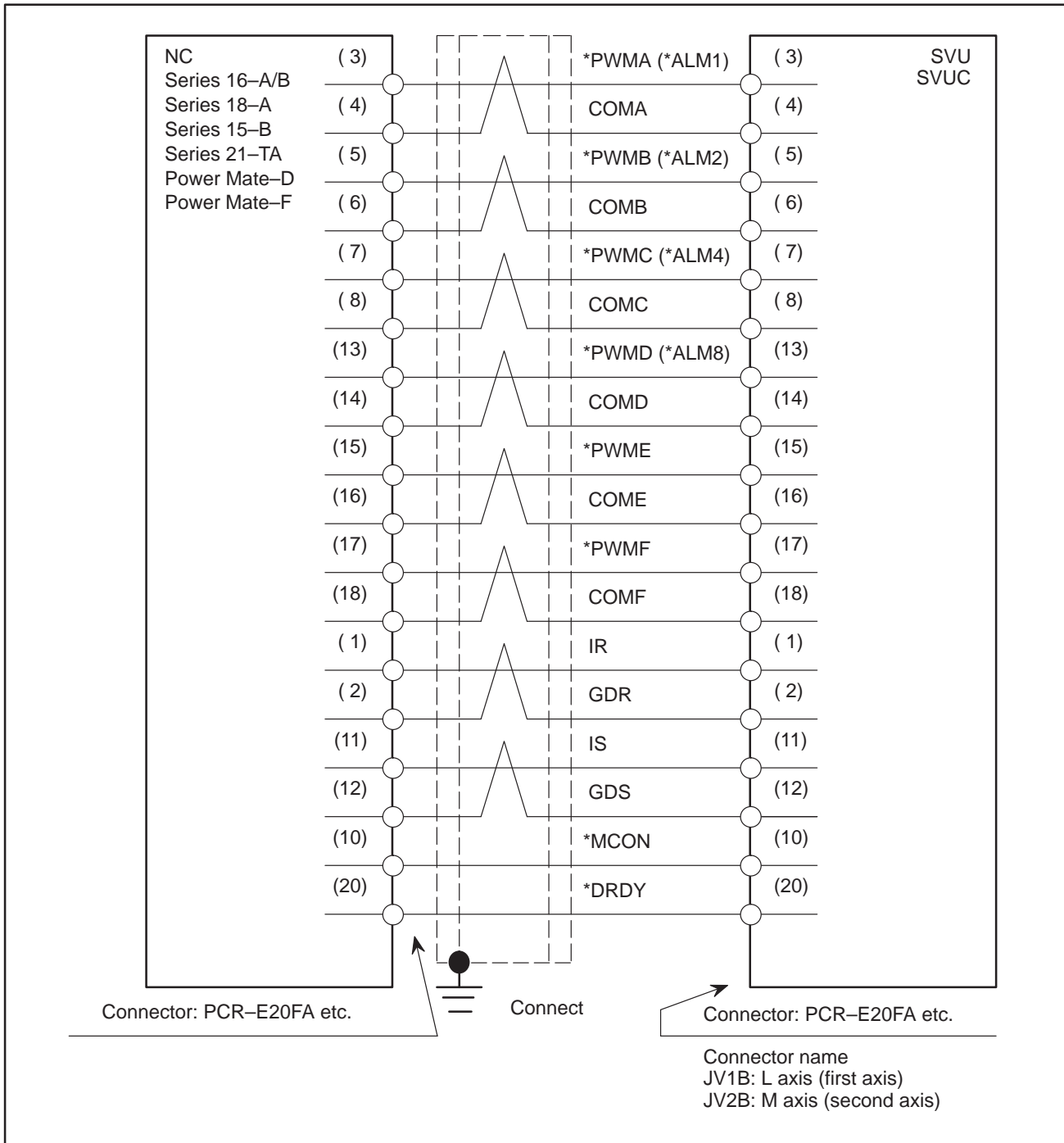

Wire material: 0.08mm² twisted pair totally shielded cable (10 pairs)

(2) For connection to Series 0-C or Series 15-A (TYPE A I/F)

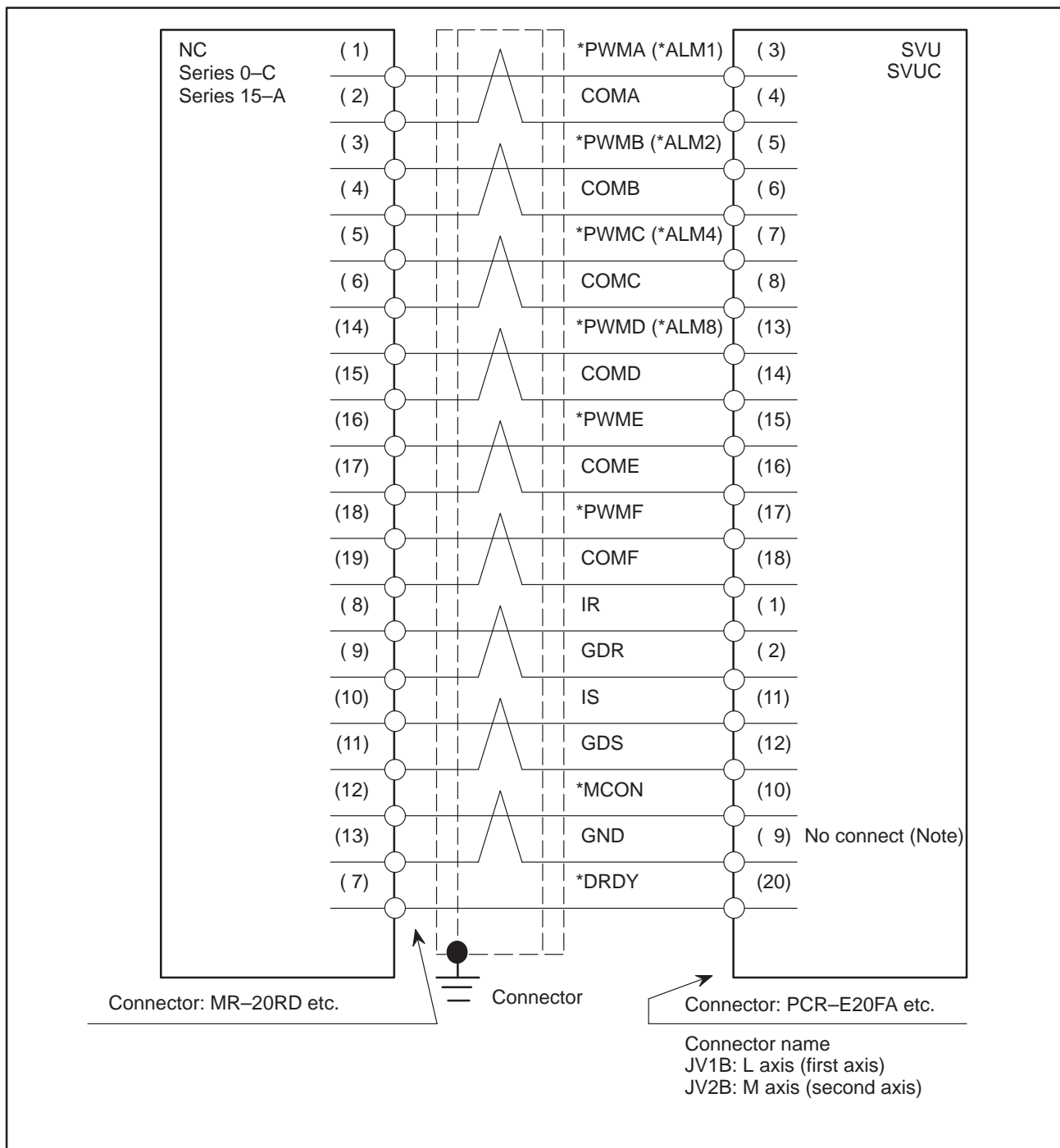

Wire material: 0.08mm twisted pair totally shielded cable (10 pairs)

CAUTION

Pin 9 of the amplifier is not connected internally. This pin should be connected to pin 13 on the NC with a twisted pair cable, the other conductor of which is *MCON.

(3) For connection to Series 16-B, Series 18-B, Series 20, Series 21-TB, Series 21-GA, or Power Mate-H (TYPE B I/F)

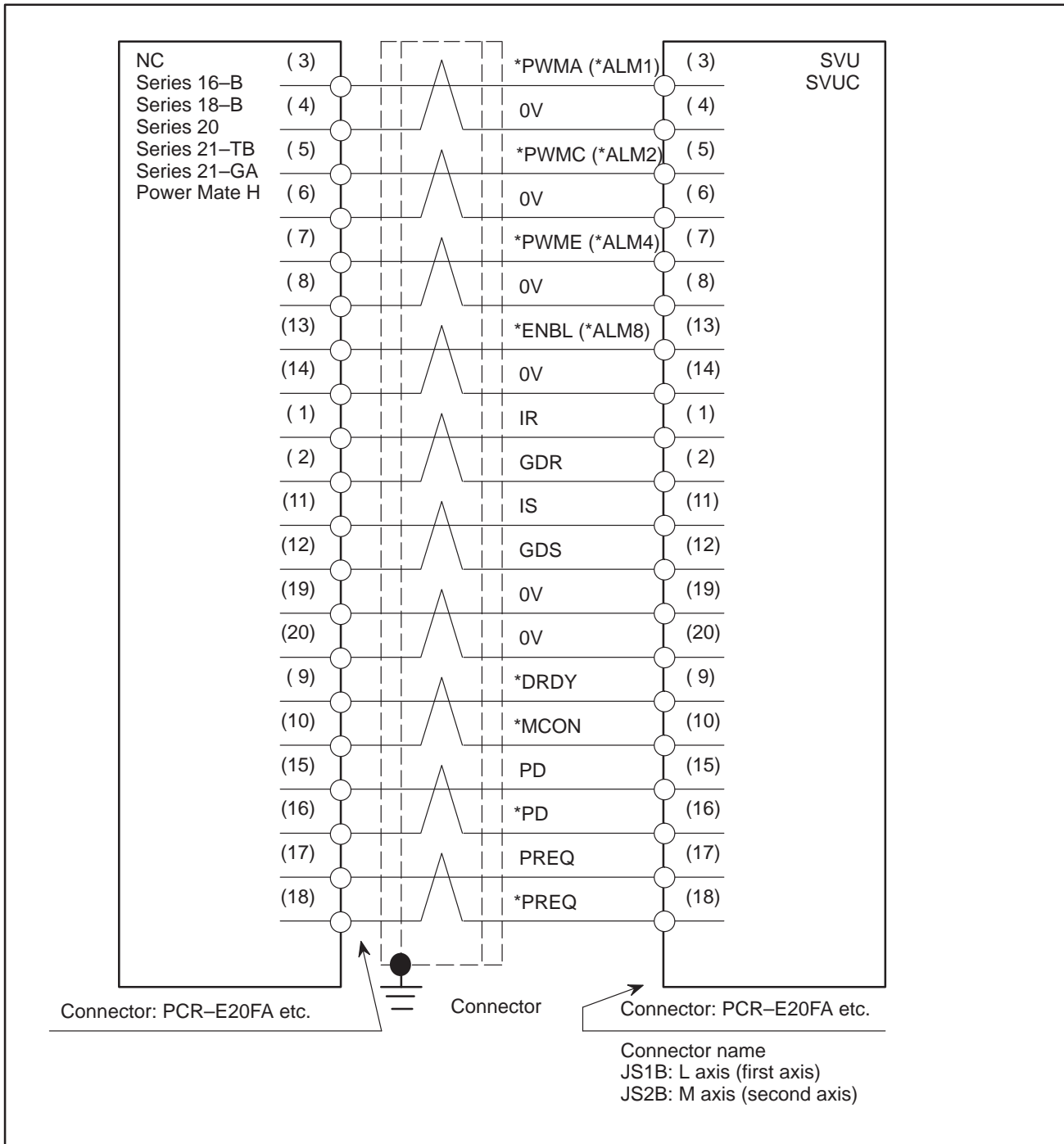

Wire material: 0.08mm twisted pair totally shielded cable (10 pairs)

CAUTION

Cables designed for the TYPE B interface can also be used with the TYPE A interface. Cables designed for the TYPE A interface, however, cannot be used with the TYPE B interface.

NOTE

Wire material of cable K1
 Recommended material of cable K1 is as follows.

Specification : A66L-001-0284#10P

Name : 10 pairs cable

Material : #28AWG×10 pairs (20 cores), Standard Length is 200m

Maker : Hitachi Cable , Oki Electric Cable

(a) Cable manufactured by HITACHI CABLE,LTD.

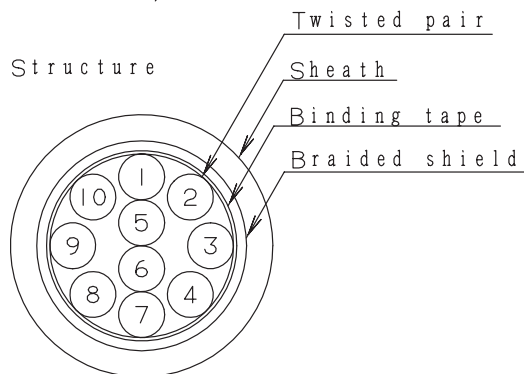

*The circled numbers corresponded to the twisted pair numbers in the table shown on the right.

Twisted pair conductor identification (HITACHI)

Twisted pair number	Insulator color	
	First conductor	Second conductor
1	Blue	White
2	Yellow	White
3	Green	White
4	Red	White
5	Purple	White
6	Blue	Brown
7	Yellow	Brown
8	Green	Brown
9	Red	Brown
10	Purple	Brown

(b) Cable manufactured by OKIELECTRIC CABLE CO.,LTD.

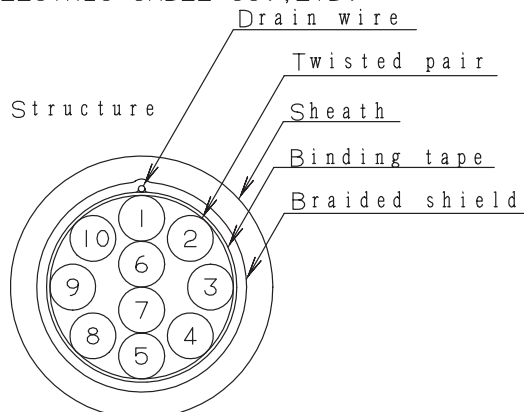

*The circled numbers corresponded to the twisted pair numbers in the table shown on the right.

Twisted pair conductor identification (OKIELECTRIC)

Twisted pair number	Insulator color	Dot mark (1 pitch)	Dot mark color	
			First conductor	Second conductor
1	Orange	-	Red	Black
2	Gray	-	Red	Black
3	White	-	Red	Black
4	Yellow	-	Red	Black
5	Pink	-	Red	Black
6	Orange	--	Red	Black
7	Gray	--	Red	Black
8	White	--	Red	Black
9	Yellow	--	Red	Black
10	Pink	--	Red	Black

(Important points)

- (1) Assign the current feedback signal (IRn, ISn, pairs of wires are 1-2, 11-12) in the center of the cable to protect from the effect of the noise. Otherwise, the motor may move abnormally. Use pair of wires 5-6 in the case of Hitachi Cable, and 6-7 in the case of Oki Electric Cable.
- (2) The cables are totally shielded. The shield should be ground to the earth plate near the NC

- (3) Associate ten twisted-pair wires with pairs of pins 1 and 2, 3 and 4, . . . , and 19 and 20 of a connector such as PCR-E20FA when connecting the pins with the pairs.

Specification

Item		Unit	Specification
Designation		—————	A66L-0001-0284#10P
Manufacturer		—————	Hitachi Cable Oki Electric Cable
Rating		—————	60°C 30V : UL2789 80°C 30V : UL80276
Material	Conductor	—————	Stranded wire of tinned annealed copper (ASIM B-286)
	Insulator	—————	Cross-linked vinyl
	Shield braid	—————	Tinned annealed copper wire
	Sheath	—————	Heat-resistant oilproof vinyl
Number of pairs		pairs	10
Conductor	Size	AWG	28
	Structure	Conductors/mm	7/0.127
	Outside diameter	mm	0.38
Insulator	Thickness	mm	0.1 (Thinnest portion : 0.08)
	Outside diameter	mm	0.58 (approx.)
	Core style	—————	UL1571 (80°C, 30V) (rating)
Twisted pair	Outside diameter	mm	1.16 (approx.)
	Pitch	mm	20 or less
Lay		—————	Collect the required number of twisted pairs into a cable, then wrap binding tape around the cable. To make the cable round, apply a cable separator as required.
Lay diameter		mm	3.5 (approx.)
Drain wire		Conductors/mm	Hitachi : Not available Oki : Available, 10/0.12
Shield braid	Element wire diameter	mm	0.12
	Braid density	%	85 or more
Sheath	Color	—————	Black
	Thickness	mm	1.0
	Outside diameter	mm	6.2 (approx.)
Standard length		m	200
Packing method		—————	Bundle
Electrical performance	Resistance	Ω /km	233 or less (at 20°C)
	Insulation resistance	M Ω -km	10 or more (at 20°C)
	Dielectric strength	V/min.	300 (AC)
Flame resistance		—————	Shall pass flame resistance test VW-ISC of UL standards.

9.3.2 Detailed Connection of Cable K2

- (1) For connection to Series 0-C or Series 15-A
(a) For model α 1/3000, α 2/2000, α 2/3000

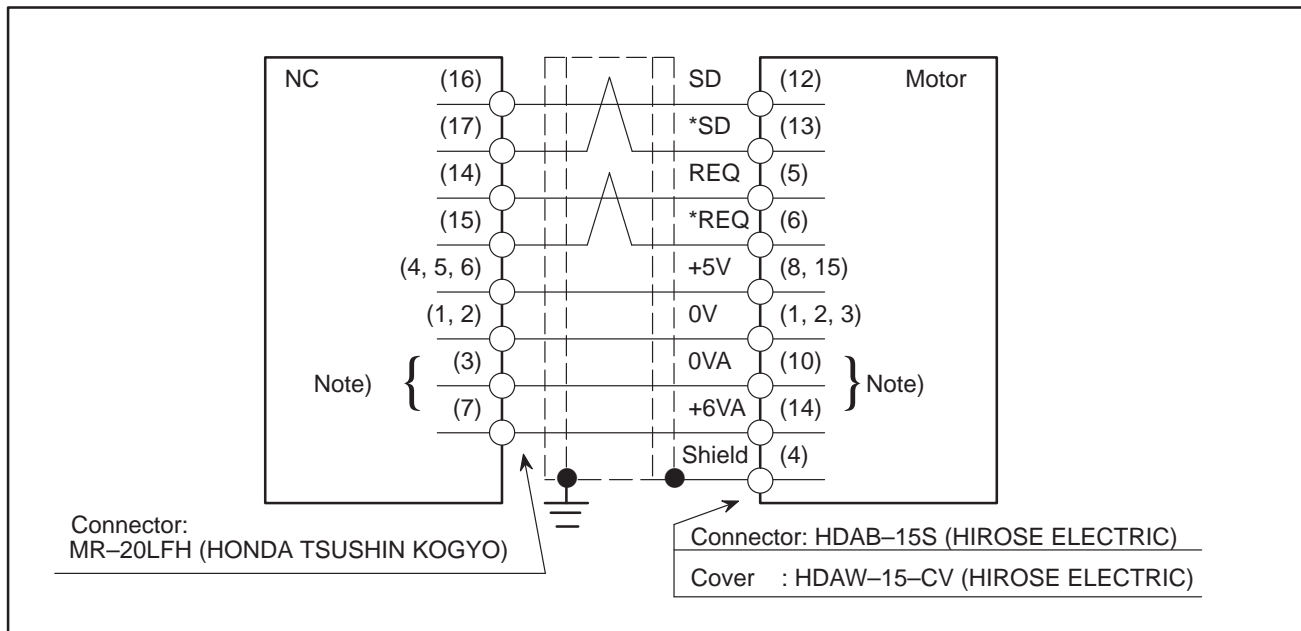

NOTE

For incremental pulse coders, pins 3 and 7 of the NC and pins 10 and 14 of the motor need not be connected. Connecting these pins, however, will not result in any problems. Therefore, a cable designed for use with an absolute pulse coder can also be used with an incremental pulse coder.

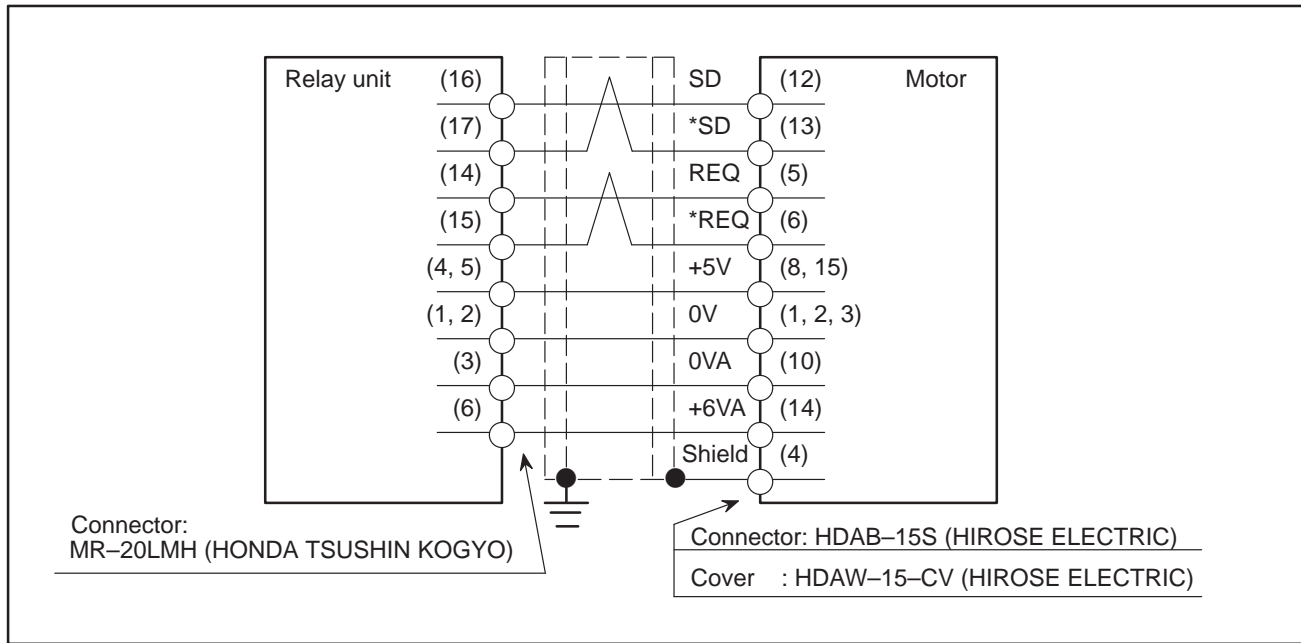

Wire material : +5V, 0V --- 0.5mm² or more × 2
 (When the cable length is 14m or less)
 : 6VA, 0VA --- 0.5mm² or more
 : SD, *SD, REQ, *REQ --- 0.18mm² or more , twisted pair

NOTE

The total resistance of the cables of pins 0V and 5V must be 0.5 Ω or less if the corresponding cables are longer than 14m.

(b) For model $\alpha 3/3000$ to $\alpha 40/2000$, $\alpha C3/2000$ to $\alpha C22/1500$

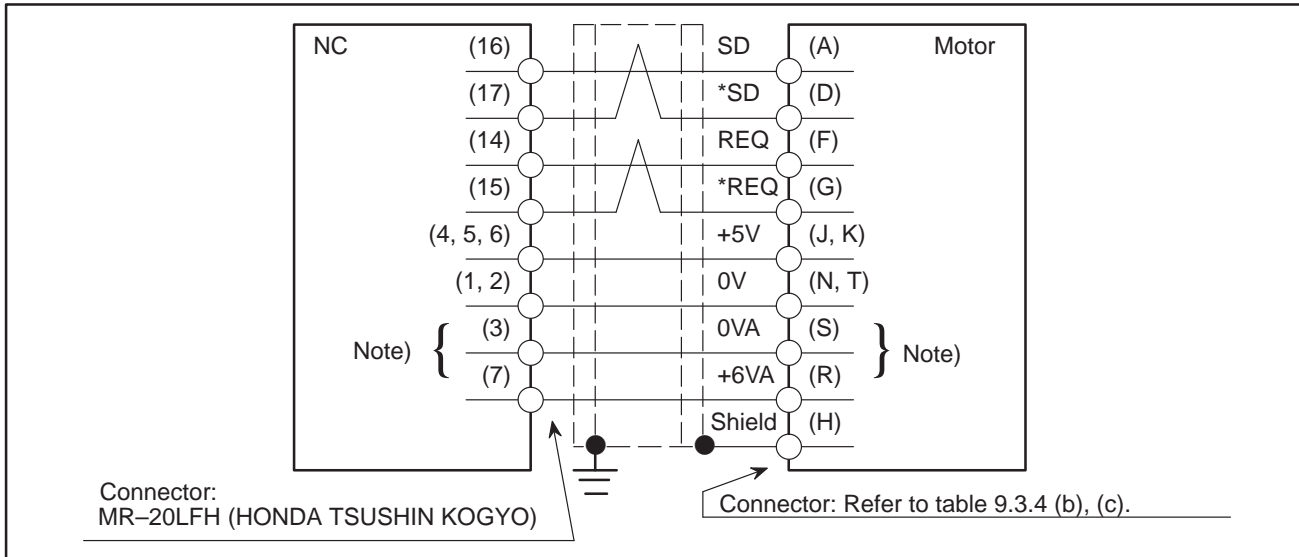

NOTE

For incremental pulse coders, pins 3 and 7 of the NC and pins S and R of the motor need not be connected. Connecting these pins, however, will not result in any problems. Therefore, a cable designed for use with an absolute pulse coder can also be used with an incremental pulse coder.

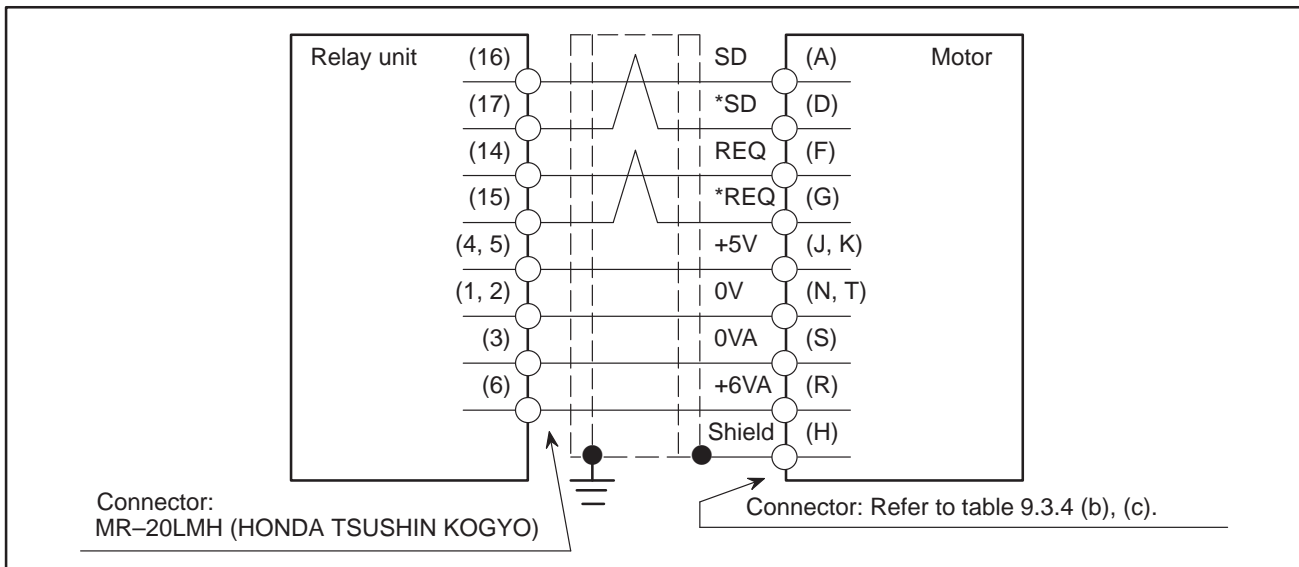

Wire material : +5V, 0V --- 0.5mm² or more × 2
 (When the cable length is 14m or less)
 : 6VA, 0VA --- 0.5mm² or more
 : SD, *SD, REQ, *REQ --- 0.18mm² or more , twisted pair

NOTE

The total resistance of the cables of pins 0V and 5V must be 0.5 Ω or less if the corresponding cables are longer than 14m.

- (2) For connection to Series 16-A/B, Series 18-A, Series 15-B, Series 21-TA, or Power Mate-D/F (TYPE A I/F)
- (a) For model $\alpha 1/3000$, $\alpha 2/2000$, $\alpha 2/3000$

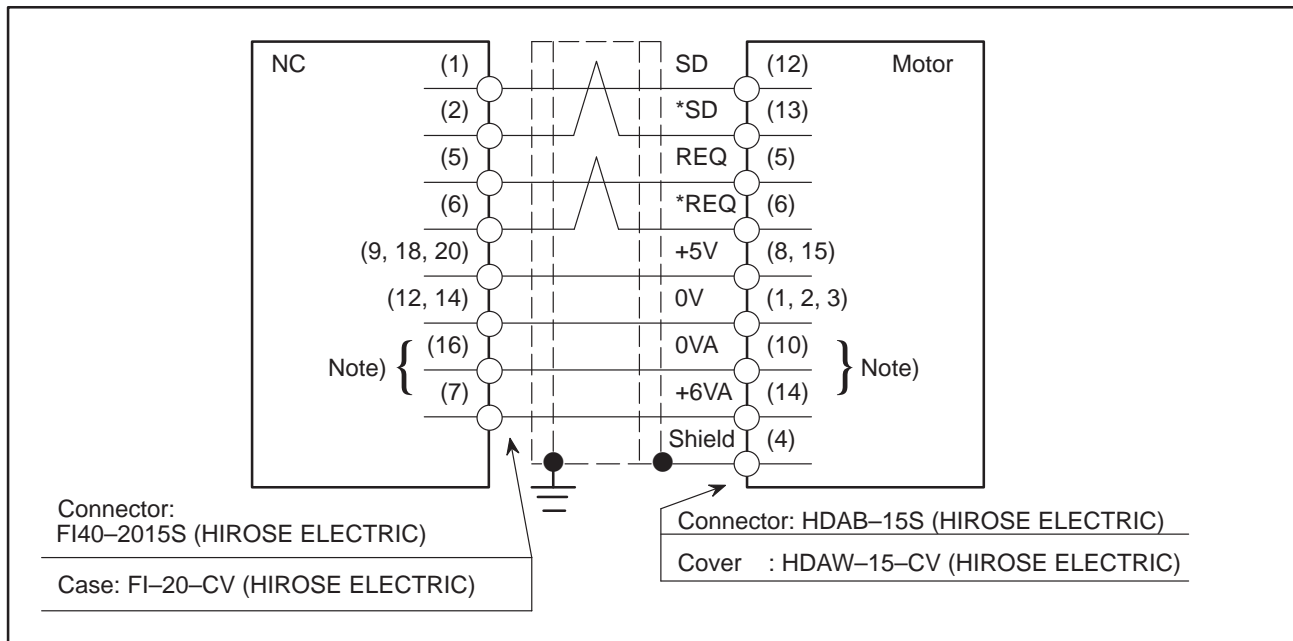

NOTE

For incremental pulse coders, pins 7 and 16 of the NC and pins 10 and 14 of the motor need not be connected. Connecting these pins, however, will not result in any problems. Therefore, a cable designed for use with an absolute pulse coder can also be used with an incremental pulse coder.

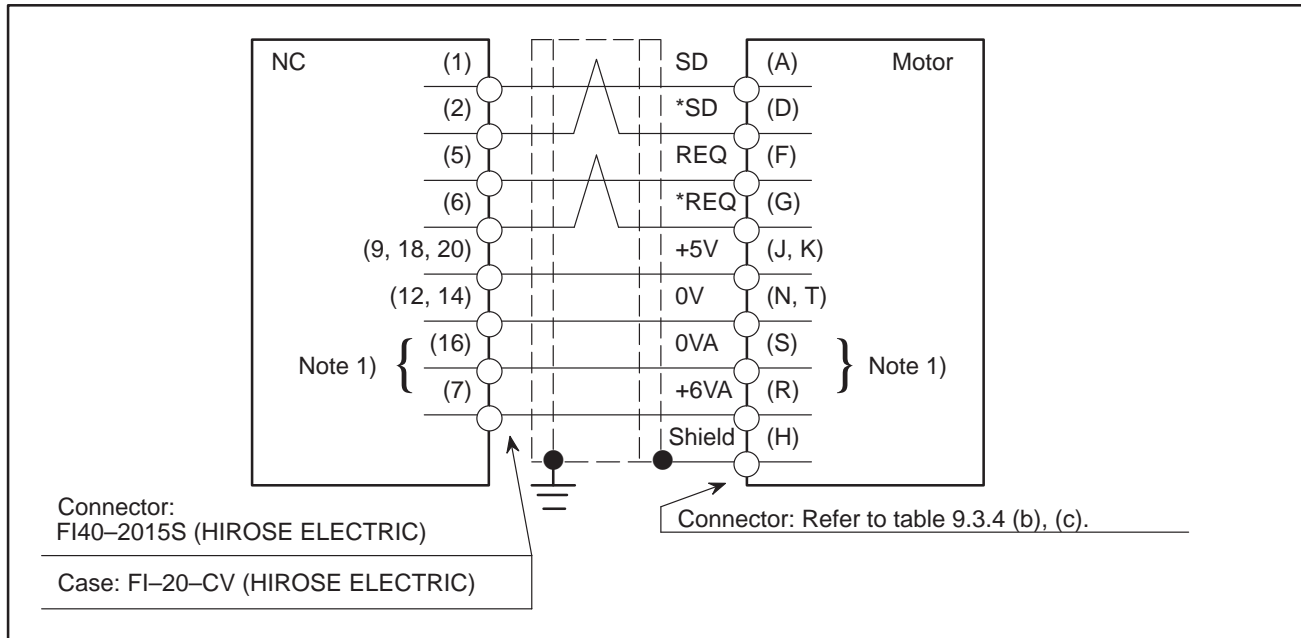
(b) $\alpha 3/3000$ to $\alpha 40/2000$, $\alpha C3/2000$ to $\alpha C22/1500$ 

Wire material : +5V, 0V --- 0.5mm^2 or more $\times 2$
 (When the cable length is 14m or less)
 : 6VA, 0VA --- 0.5mm^2 or more
 : SD, *SD, REQ, *REQ --- 0.18mm^2 or more, twisted pair

NOTE

- 1 For incremental pulse coders, pins 7 and 16 of the NC and pins S and R of the motor need not be connected. Connecting these pins, however, will not result in any problems. Therefore, a cable designed for use with an absolute pulse coder can also be used with an incremental pulse coder.
- 2 The total resistance of the cables of pins 0V and 5V must be $0.5\ \Omega$ or less if the corresponding cables are longer than 14m.

- (3) For connection to Series 16-B, Series 18-B, Series 20, Series 21-GA, Series 21-TB, or Power Mate H (TYPE B I/F)
- (a) For model α 1/3000, α 2/2000, α 2/3000

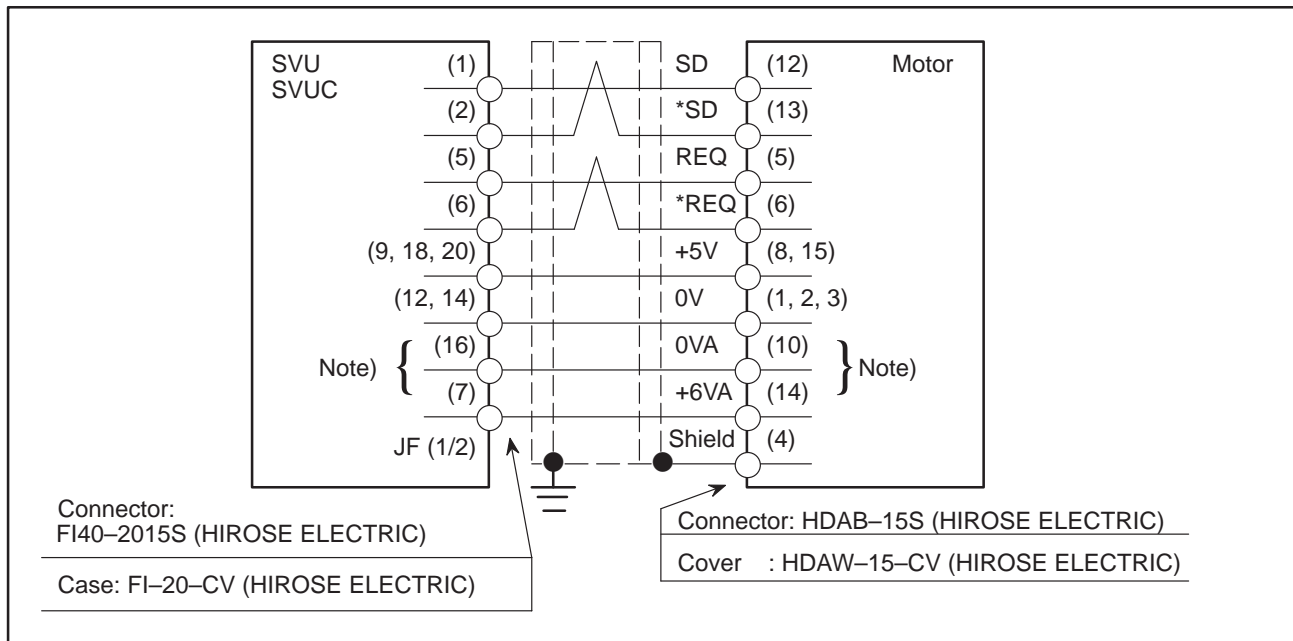

NOTE

For incremental pulse coders, pins 7 and 16 of the NC and pins 10 and 14 of the motor need not be connected. Connecting these pins, however, will not result in any problems. Therefore, a cable designed for use with an absolute pulse coder can also be used with an incremental pulse coder.

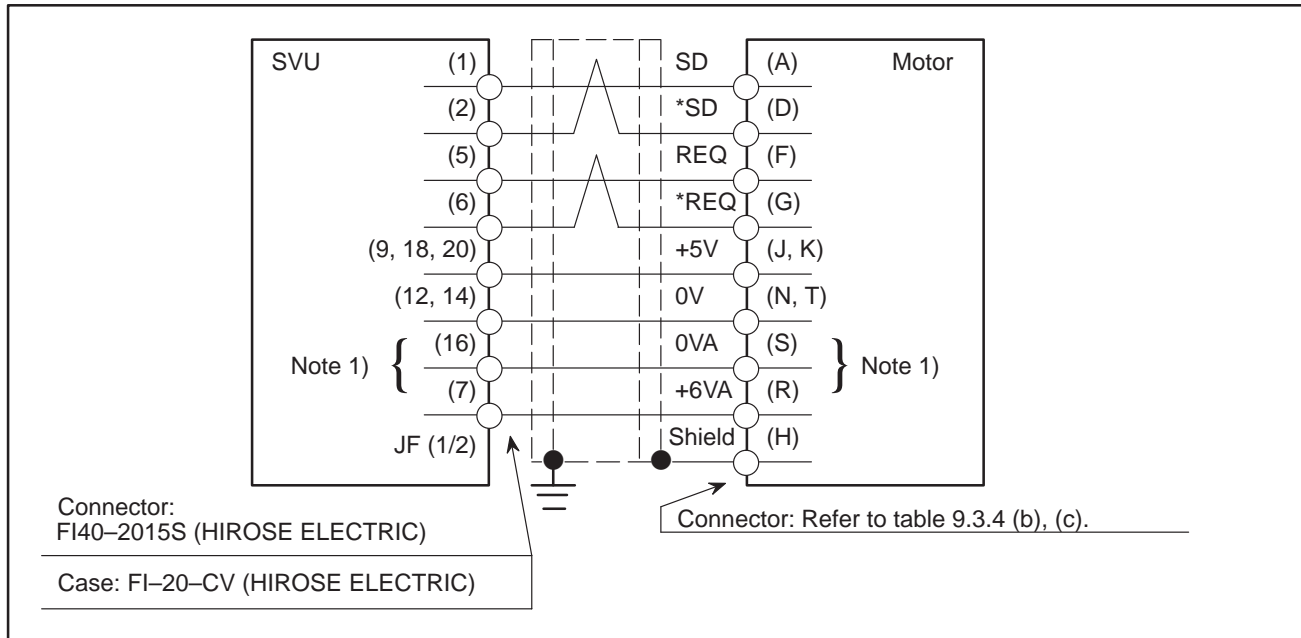
(b) For model α 3/3000 to α 40/2000, α C3/2000 to α C22/1500

Wire material : +5V, 0V --- 0.5mm^2 or more \times 2
 (When the cable length is 14m or less)
 : 6VA, 0VA --- 0.5mm^2 or more
 : SD, *SD, REQ, *REQ --- 0.18mm^2 or more , twisted pair

NOTE

- 1 For incremental pulse coders, pins 7 and 16 of the NC and pins S and R of the motor need not be connected. Connecting these pins, however, will not result in any problems. Therefore, a cable designed for use with an absolute pulse coder can also be used with an incremental pulse coder.
- 2 The total resistance of the cables of pins 0V and 5V must be $0.5\ \Omega$ or less if the corresponding cables are longer than 14m.

9.3.3 Detailed Connection of Cable K3

- (1) Power supply voltage is 200, 220, 230VAC and the system conform with the European standard.

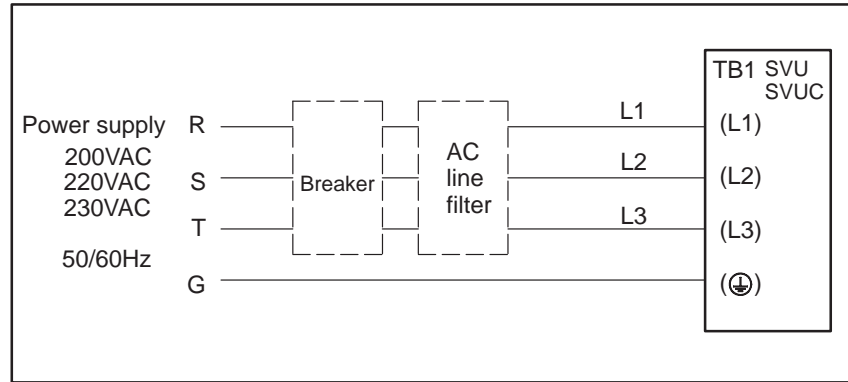

- (2) Power supply voltage is 380, 415, or 460 VAC, and the system has not been approved to display the CE marking (machinery directive).

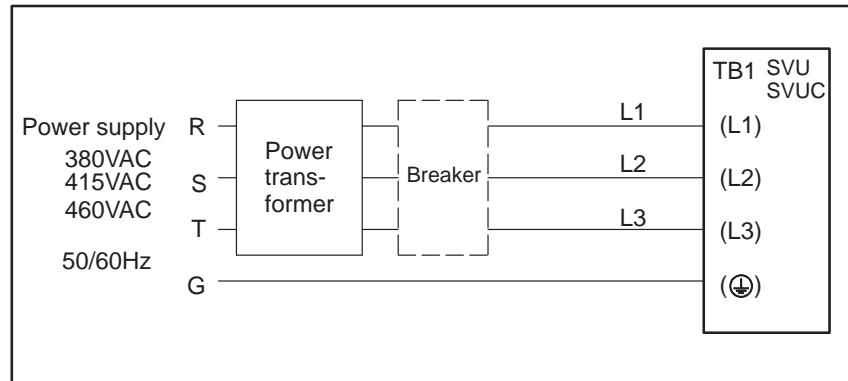

- (3) Power supply voltage is 380, 415, or 460 VAC, and the system has been approved to display the CE marking (machinery directive).

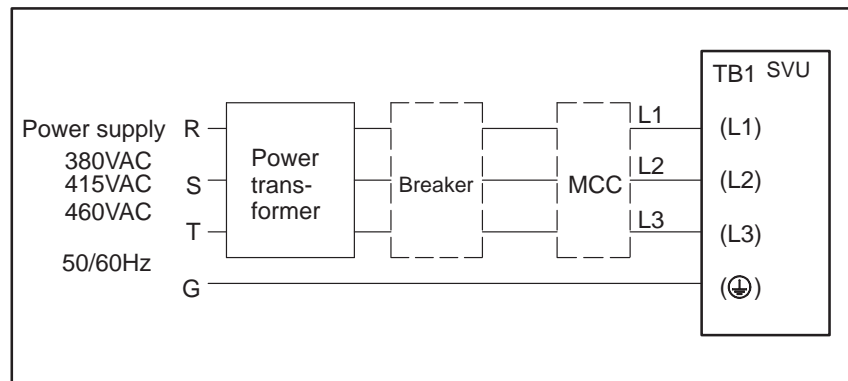

NOTE

- 1 When the power transformer is used, the AC line filter can be omitted.
- 2 A system using the SVUC will not be able to gain approval to display the CE marking (machinery directive).

Table 9.3.3 Specification of Cable K3

Amplifier	Cable		Screw of terminal
	Vinyl cabtyre cable Note 1)	Heat-resistive vinyl cable Note 2)	
SVU1-12, 20 SVUC1-4, 12	2.0 mm ² or more	2.0 mm ² or more	M4
SVU1-40, 80 SVU2-□/□ SVUC1-40, 80 SVUC2-□/□	3.5 mm ² or more	3.5 mm ² or more	M4
SVU1-130 SVUC1-130	5.5 mm ² or more	5.5 mm ² or more	M4

NOTE

- 1 4-cores vinyl cabtyre cable (JIS C 3312)
- 2 Nonflammable polyflex cable (maximum conductor temperature : 105°C)
(LMFC manufactured by Furukawa Electric Co. , or equivalent)

9.3.4 Detailed Connection of Cable K4

(1) For model α0.5/3000

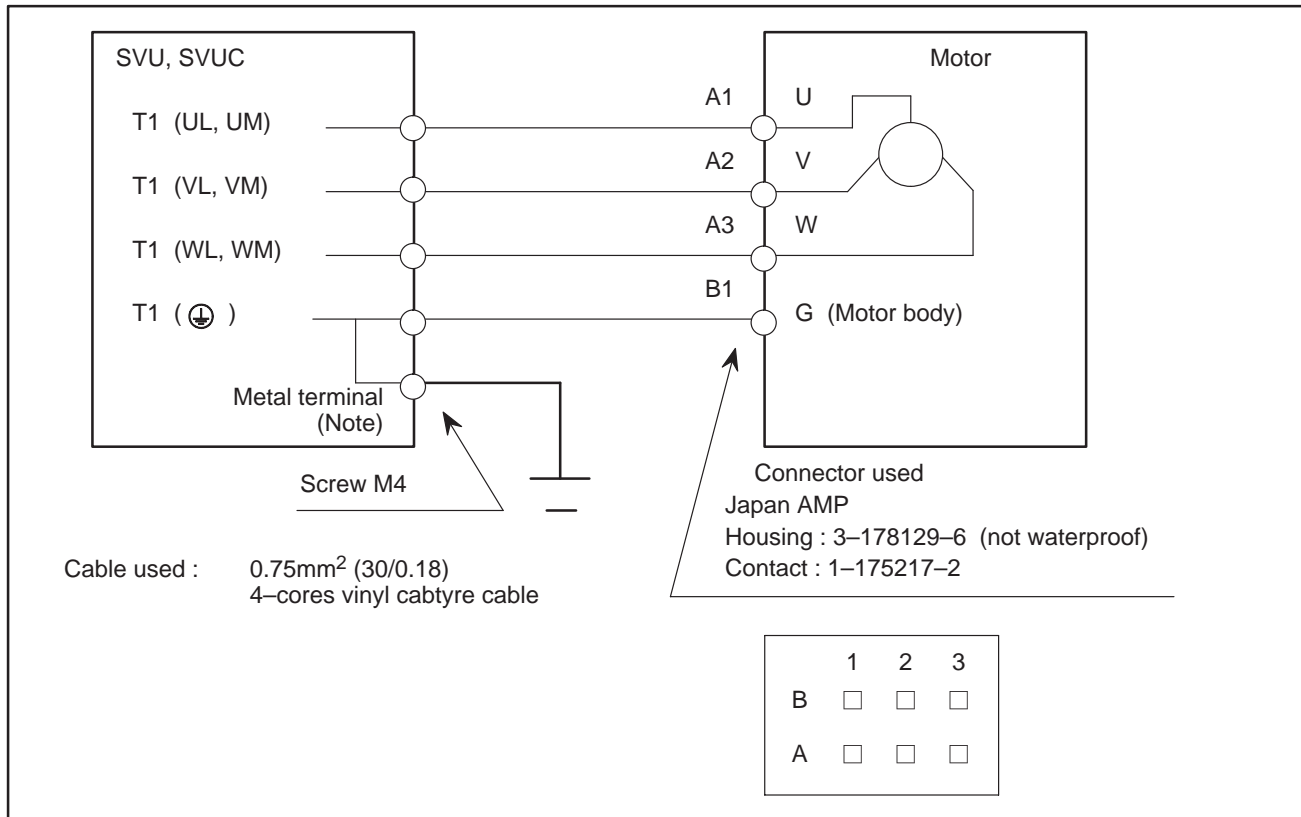

NOTE
The SVUC does not require metal terminal connection.

(2) For model α1/3000 to α2/3000

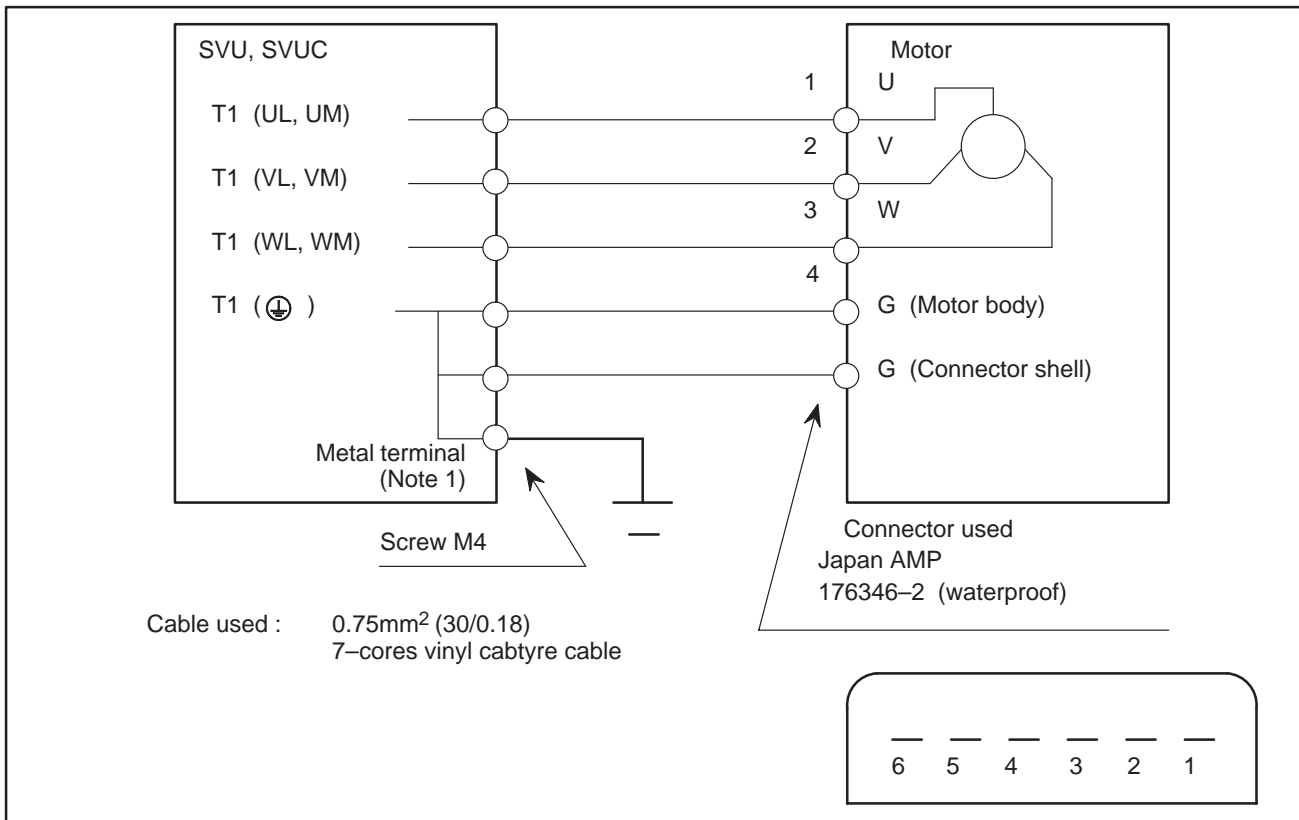

NOTE

- 1 The SVUC does not require metal terminal connection.
- 2 The connector shell must be grounded if the machine must comply with European standards.

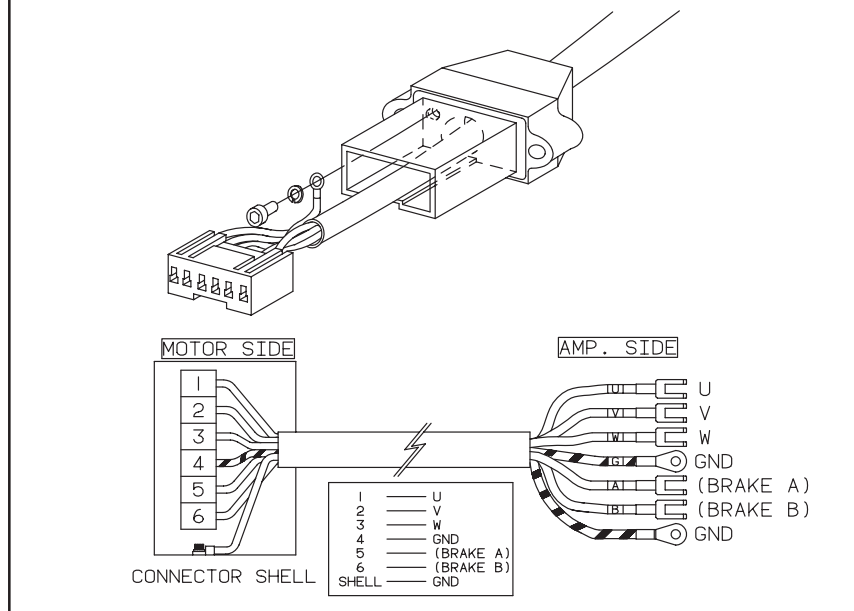

(3) For model α3/3000 to α6/3000, αC3/2000 to αC6/2000, αM3/3000 to αM9/3000, αL3/3000 to αL9/3000, αE1/3000 to αE6/2000

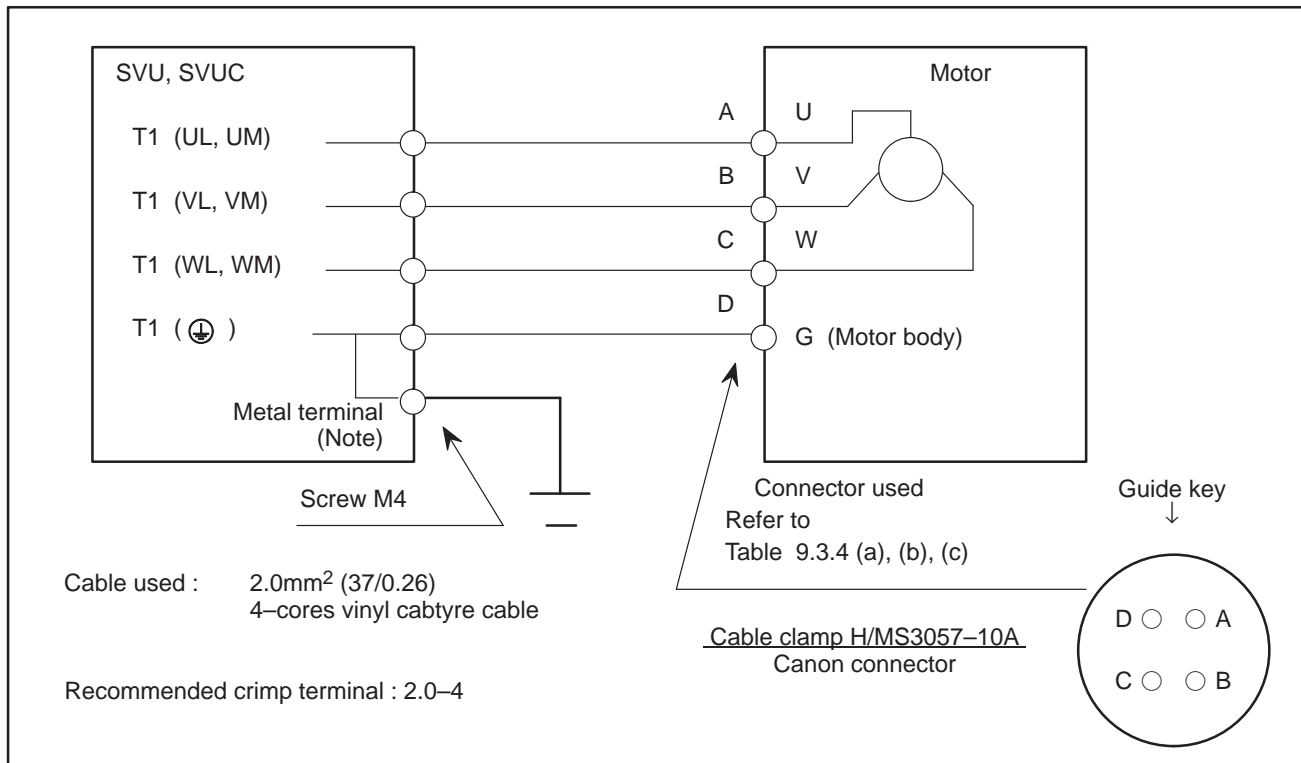

NOTE

The SVUC does not require metal terminal connection.

(4) For model α 12/2000 to α 30/1200, α C12/2000 to α C22/1500

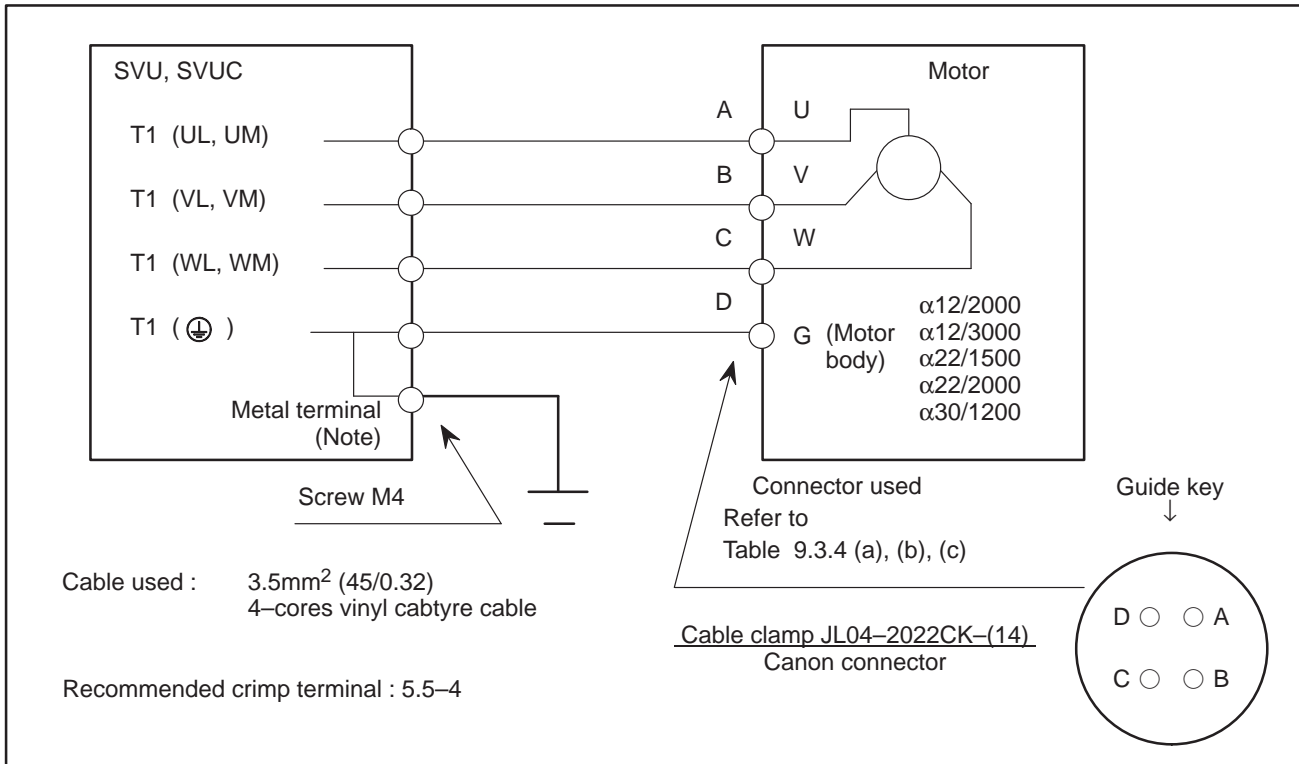

NOTE

The SVUC does not require metal terminal connection.

(5) For model $\alpha 22/3000$, $\alpha 30/2000$, $\alpha 30/3000$, $\alpha 40/2000$, $\alpha 40/2000$ (with fan), $\alpha L25/3000$, $\alpha L50/2000$

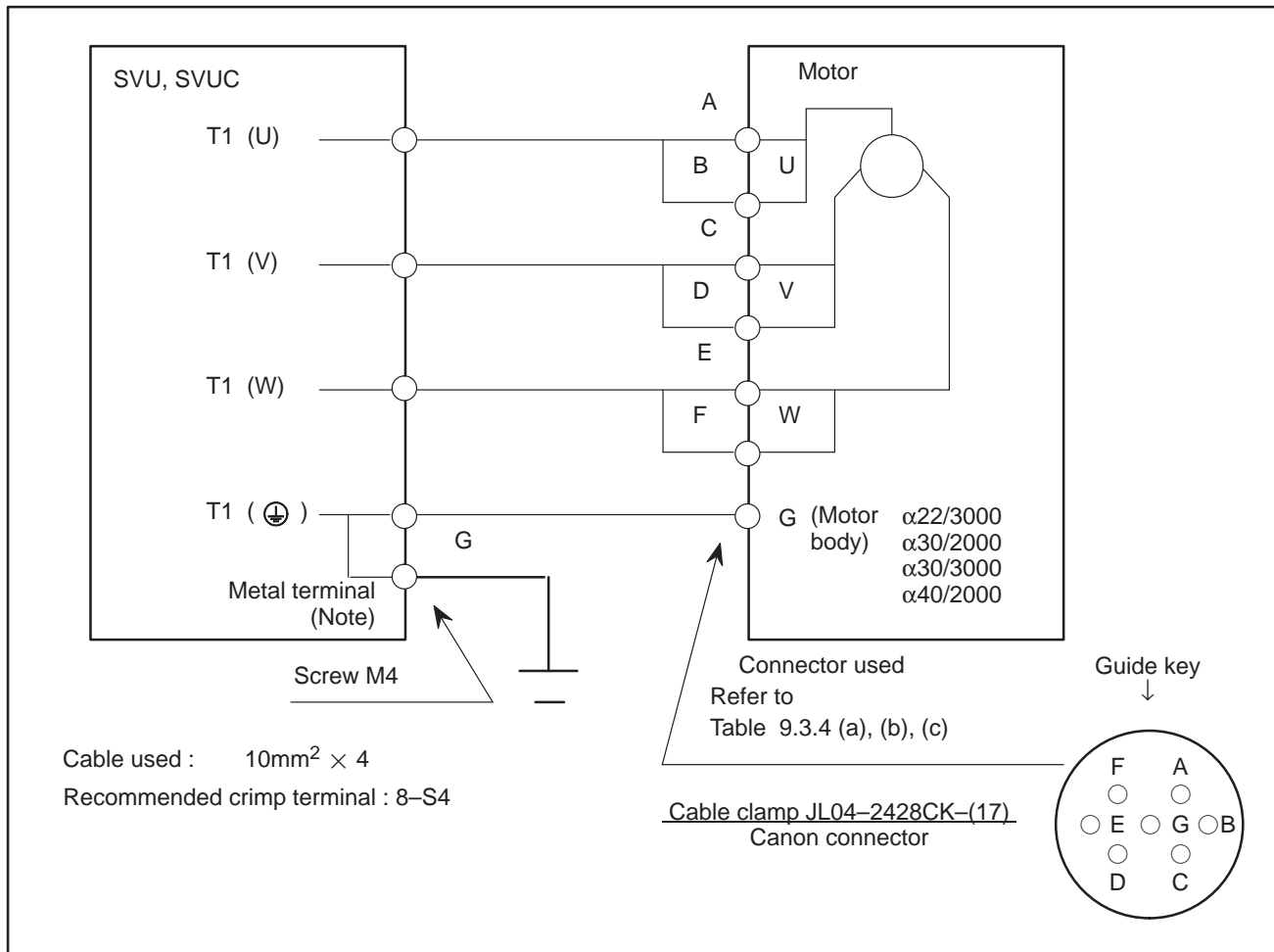

NOTE

The SVUC does not require metal terminal connection.

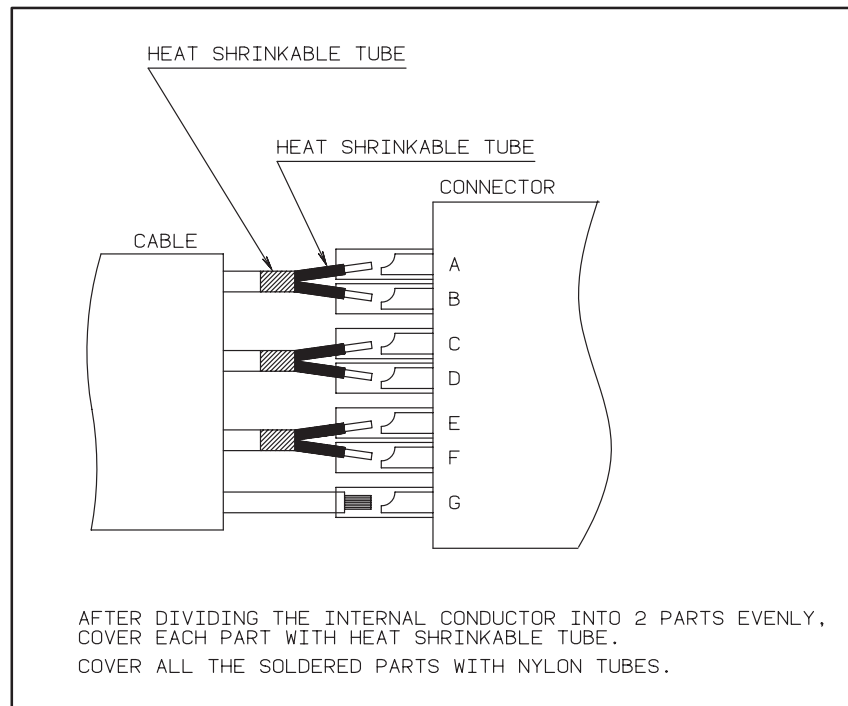
**Important point**

When the motor do not ground to the machine (cabinet) that the motor is mounted, connect the ground of motor and the ground of amplifier with the cable to absorb the noise. In this case, use the cable thicker than 1.25mm^2 which is not the line inside the power cable, and install aloof from power cable as possible.

By this connection, the influence of the switching noise can be reduced.

Table 9.3.4 (a) Cable side plug specifications (TUV recognized)

Motor model		α3/3000 α6/2000 α6/3000 α3/3000HV α6/3000HV αC3/2000 αC6/2000	αM3/3000 αM6/3000 αM9/3000 αL3/3000 αL6/3000 αL9/3000	α12/2000 α12/3000 α22/1500 α22/2000 α30/1200 α12/3000HV α22/3000HV	α30/3000HV αC12/2000 αC22/1500	α22/3000 α30/2000 α30/3000 α40/2000 α40/2000 (with fan) αL25/3000 αL50/2000
For power	With a straight adapter	H/MS3106A18-10S-D-T-(10) (Hirose Electric)		JL04V-6A22-22SE-EB (JAE)		JL04V-6A24-10SE (G) -EB (JAE)
	With an angle adapter	H/MS3108B18-10S-D-T-(10) (Hirose Electric)		JL04V-8A22-22SE-EB (JAE)		JL04V-8A24-10SE (G) -EB (JAE)
	For conduit attachment	H/MS3106A18-10S-D-T-(13) (Hirose Electric)		JL04V-6A22-22SE (JAE)		JL04V-6A24-10SE (G) (JAE)

NOTE

- 1 JAE : Japan Aviation Electronics Industry
- 2 The waterproof of the single block type pluge for conduit attachment should be considered with the adapter for it.
For more detail, please contact the connector maker.

Table 9.3.4 (b) Cable side plug specifications (waterproof)

Motor model		α3/3000 α6/2000 α6/3000 α3/3000HV α6/3000HV αC3/2000 αC6/2000	αM3/3000 αM6/3000 αM9/3000 αL3/3000 αL6/3000 αL9/3000	α12/2000 α12/3000 α22/1500 α22/2000 α30/1200 α12/3000HV α22/3000HV	α30/3000HV αC12/2000 αC22/1500	α22/3000 α30/2000 α30/3000 α40/2000 α40/2000 (with fan) αL25/3000 αL50/2000
For power	With a straight adapter	H/MS3106A18-10S (10) (Hirose Electric)		H/MS3106A22-22S (10) (Hirose Electric)		H/MS3106A24-10S (10) (Hirose Electric)
	With an angle adapter	H/MS3108B18-10S (10) (Hirose Electric)		H/MS3108B22-22S (10) (Hirose Electric)		H/MS3108B24-10S (10) (Hirose Electric)
	For conduit attachment (With no adapter)	JL04-6A18-10S-J1(A72) (JAE) H/MS3106A18-10S (13) (Hirose Electric)		JL04-6A22-22S-J1(A72) (JAE) H/MS3106A22-22S (13) (Hirose Electric)		JL04-6A24-10S-J1(A72) (JAE) H/MS3106A24-10S (13) (Hirose Electric)
For signal	With a straight adapter	H/MS3106A20-29SW (11) (Hirose Electric)				
	With an angle adapter	H/MS3108B20-29SW (11) (Hirose Electric)				
	For conduit attachment (With no adapter)	JA06A-20-29SW-J1-(A72) (JAE) H/MS3106A20-29SW (14) (Hirose Electric)				

NOTE

JAE : Japan Aviation Electronics Industry

Table 9.3.4 (c) Cable side plug specifications (non-waterproof)

Motor model		α3/3000 α6/2000 α6/3000 α3/3000HV α6/3000HV αC3/2000 αC6/2000	αM3/3000 αM6/3000 αM9/3000 αL3/3000 αL6/3000 αL9/3000	α12/2000 α12/3000 α22/1500 α22/2000 α30/1200 α12/3000HV α22/3000HV	α30/3000HV αC12/2000 αC22/1500	α22/3000 α30/2000 α30/3000 α40/2000 α40/2000 (with fan) αL25/3000 αL50/2000
For power	With a straight adapter	MS3106B18-10S-(A72) (JAE) H/MSA3106A18-10S (10) (Hirose Electric)	MS3106B22-22S-(A72) (JAE) H/MSA3106A22-22S (10) (Hirose Electric)	MS3106B24-10S-(A72) (JAE) H/MSA3106A24-10S (10) (Hirose Electric)		
	With an angle adapter	JL04-8B18-10S-(A72) (JAE) H/MSA3108B18-10S (10) (Hirose Electric)	JL04-8B22-22S-(A72) (JAE) H/MSA3108B22-22S (10) (Hirose Electric)	JL04-8B24-10S-(A72) (JAE) H/MSA3108B24-10S (10) (Hirose Electric)		
For signal	With a straight adapter	MS3106B20-29SW-(A72) (JAE)		H/MSA3106A20-29SW (11) (Hirose Electric)		
	With an angle adapter	MS3108B20-29SW-(A72) (JAE)		H/MSA3108B20-29SW (11) (Hirose Electric)		

NOTE

JAE : Japan Aviation Electronics Industry

9.3.5 Detailed Connection of Cable K5

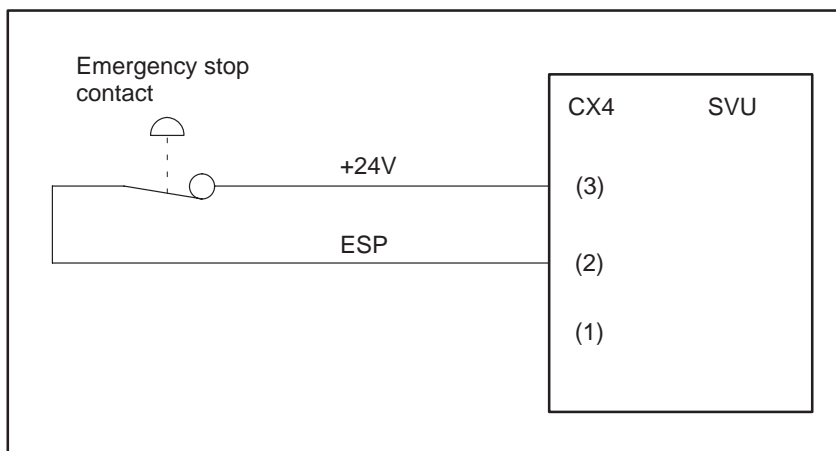

Cable specification : Two-core vinly cabtyre cable JIS C 3312
 Conductor 1.25mm² (50/0.18) Sheath PVC 9.6 φ
 Connector specification : Cnnector manufactured by AMP
 Receptacle housing: 1-178128-3
 Receptacle contact : 1-175218-2

CAUTION

- The contact input signal is defined as follows:
- ① The external contact should be rated at least 30 VDC, 100 mA.
 - ② When a square wave input is used without a contact, the effective levels (voltage across the input terminals) are:
 Low level, logical 0 : 2 V or lower
 High level, logical 1 : 20 V or higher

9.3.6 Detailed Connection of Cable K6

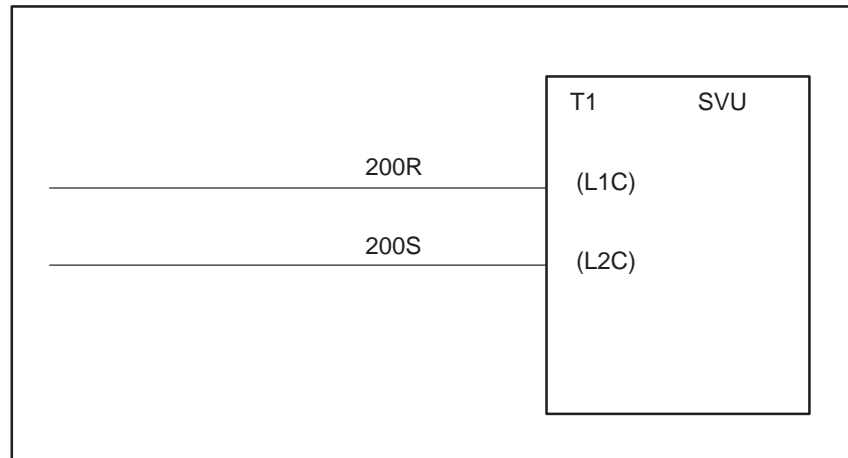

Cable specification : Two-core vinly cabtyre cable JIS C 3312
 Conductor 1.25mm^2 (50/0.18) Sheath PVC 9.6ϕ
 Crimp terminal : 2-4

9.3.7 Detailed Connection of Cable K7

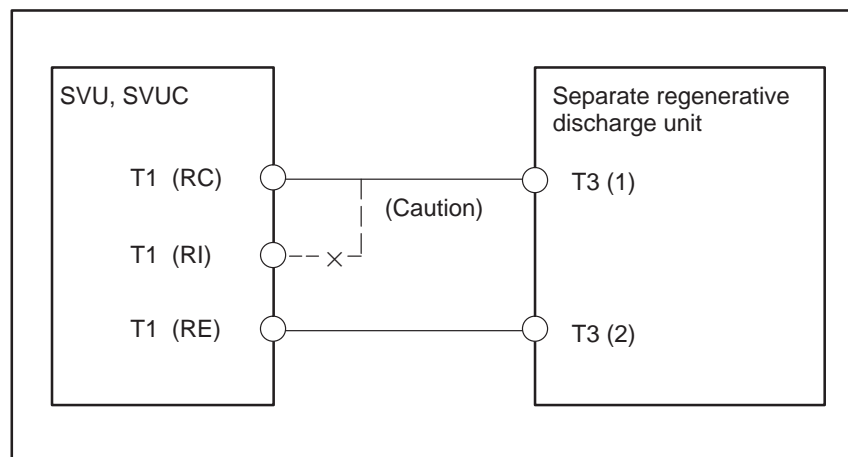

Cable specification : Two-core vinly cabtyre cable JIS C 3312
 Conductor 2.0mm^2 (37/0.26) Sheath PVC 10.5ϕ
 Crimp terminal : 2-4

CAUTION

When the separate regenerative discharge unit is used, remove the short bar between T1 (RC) and T1 (RI).

9.3.8 Detailed Connection of Cable K8

(a) When the transformer is not used

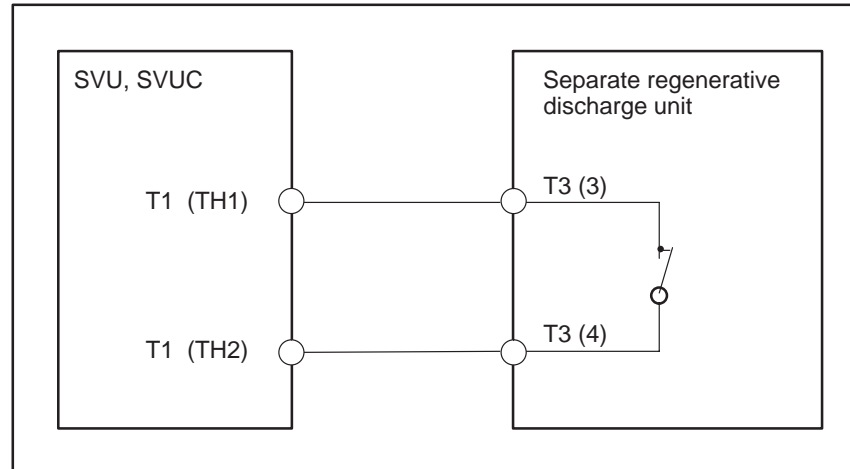

Cable specification : Two-core vinly cabtyre cable JIS C 3312
 Conductor 0.75mm^2 (30/0.18) Sheath PVC 8.8ϕ
 Crimp terminal : 1.25-4

CAUTION

When the cable K8 is connected, set the switch correctly.
 See Section 3.4 for details.

(b) When the transformer is used

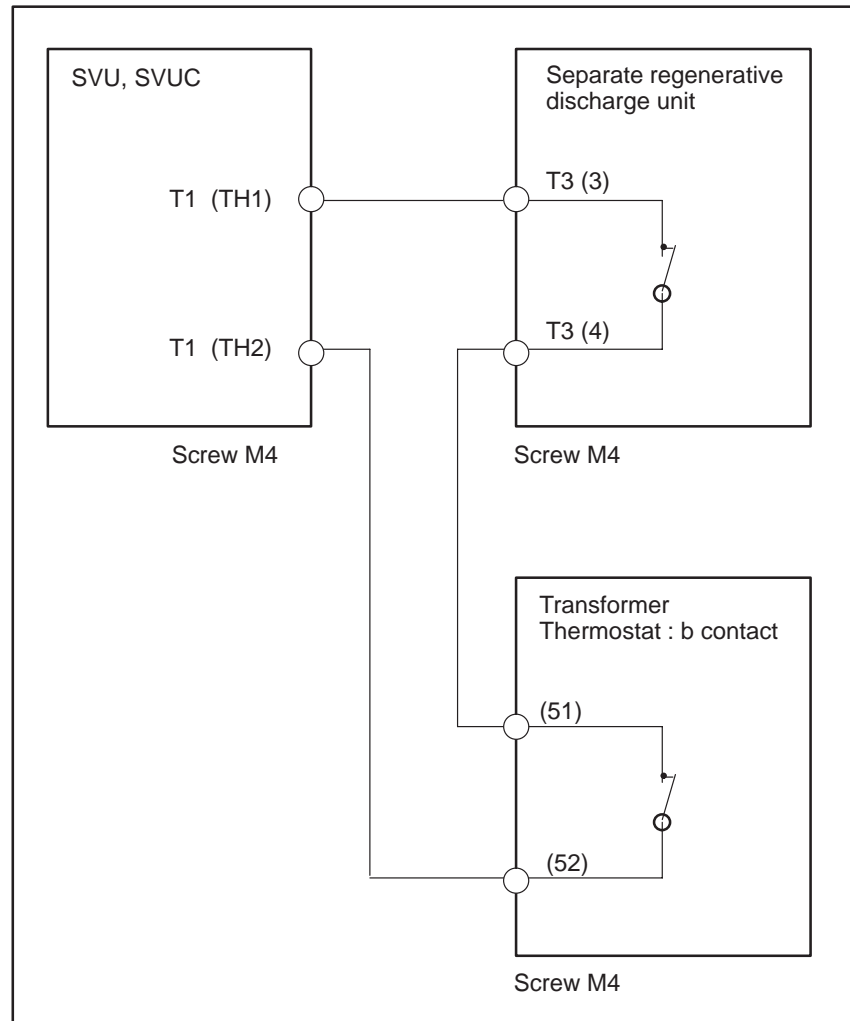

Cable specification : Two-core vinly cabtyre cable JIS C 3312
 Conductor 0.75mm^2 (30/0.18) Sheath PVC 8.8ϕ
 Crimp terminal : 1.25-4

CAUTION

When the cable K8 is connected, set the switch correctly.
 See Section 3.4 for details.

9.3.9 Detailed Connection of Cable K9

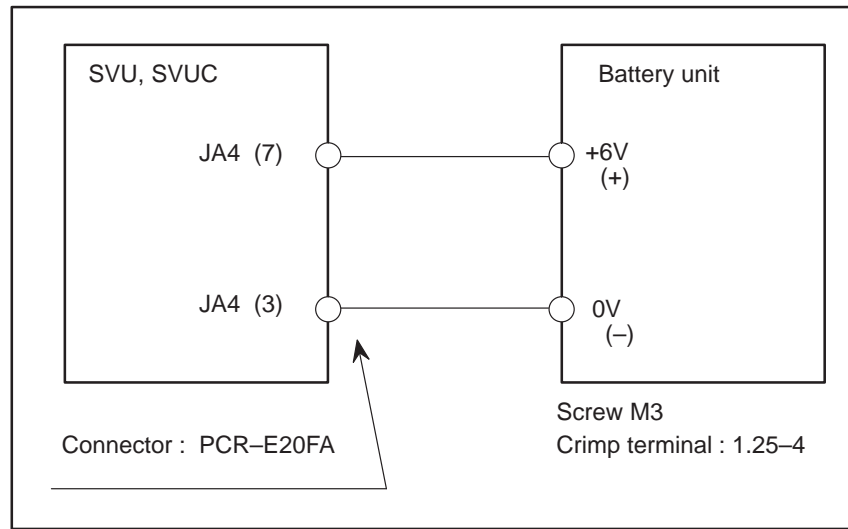

Cable specification : Two-core vinly cabtyre cable JIS C 3312
Conductor 0.75mm² (30/0.18)

9.3.10 Detailed Connection of Cable K10

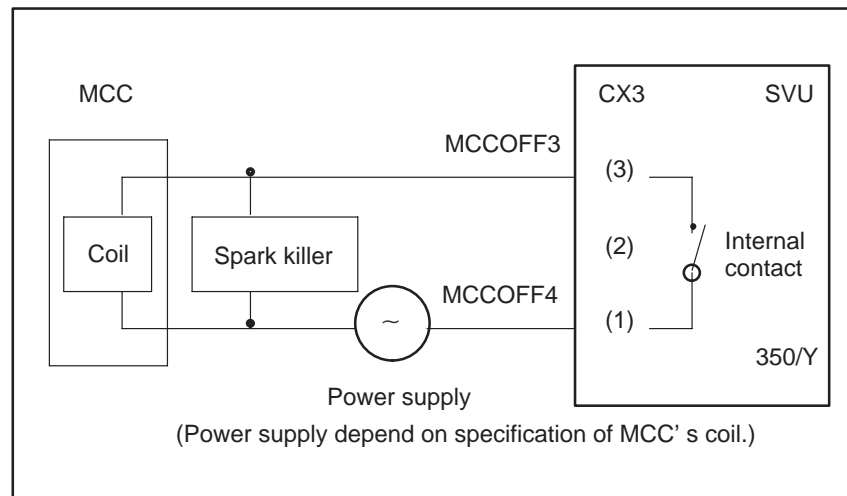

Cable specification : Two-core vinly cabtyre cable JIS C 3312

Conductor 1.25mm^2 (50/0.18) Sheath PVC 9.6 ϕ

Connector specification : Cnnector manufactured by AMP

Receptacle housing : 2-178128-3

Receptacle contact : 1-175218-2

Specification of Internal contact	Resistor load ($\cos\phi=1$)	Inductance load ($\cos\phi=0.4$, L/R=7msec)
Rated load	250VAC, 5A / 30VDC, 5A	250VAC, 2A / 30VDC, 2A
Max. current	5A	5A

Spark killer : Spark killer to fit the MCC must be used to protect the contact of MCC' s coil.

9.3.11 Detailed Connection of Cable K11

(1) For SVU1-130, SVUC1-130

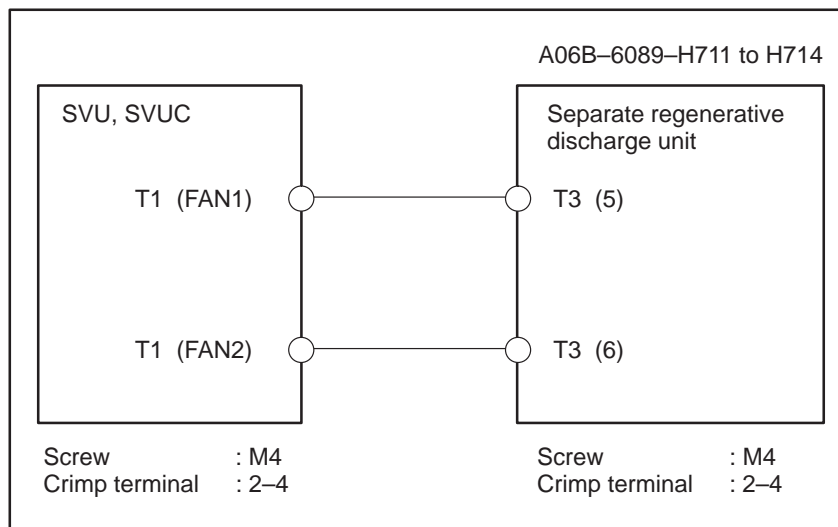

Cable specification : Two-core vinly cabtyre cable JIS C 3312
or heat-resistive vinyl cable
Conductor 2.0mm² (37/0.26)

(2) For except for SVU1-130, SVUC1-130

(a) SVU

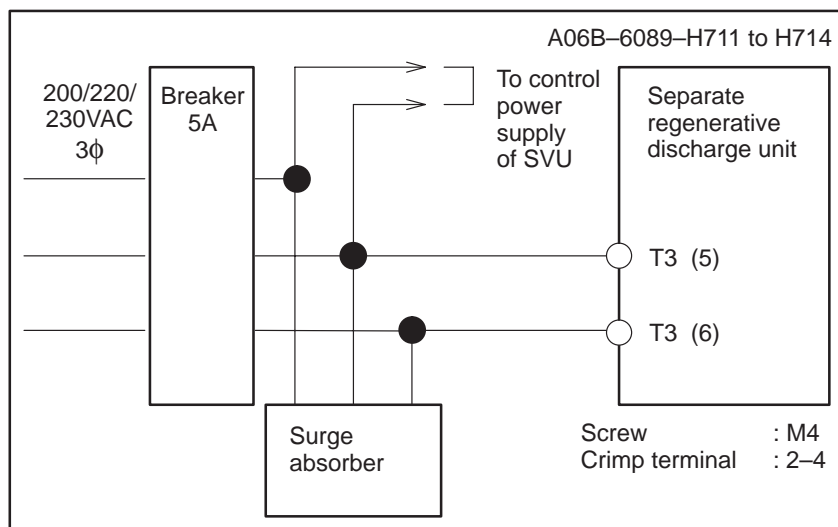

Cable specification : Two-core vinly cabtyre cable JIS C 3312
or heat-resistive vinyl cable
Conductor 2.0mm² (37/0.26)

(b) SVUC

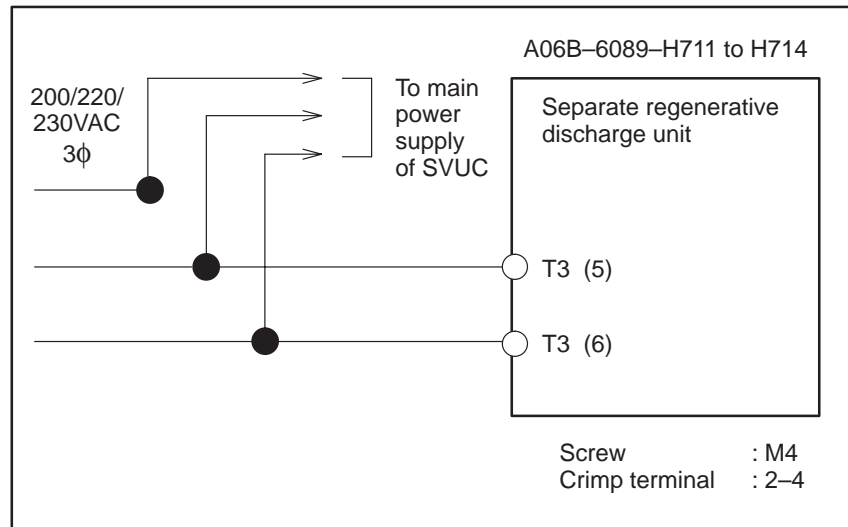

Cable specification : Two-core vinly cabtyre cable JIS C 3312
or heat-resistive vinyl cable
Conductor 2.0mm² (37/0.26)

9.3.12
Detailed Connection
of Cable K12

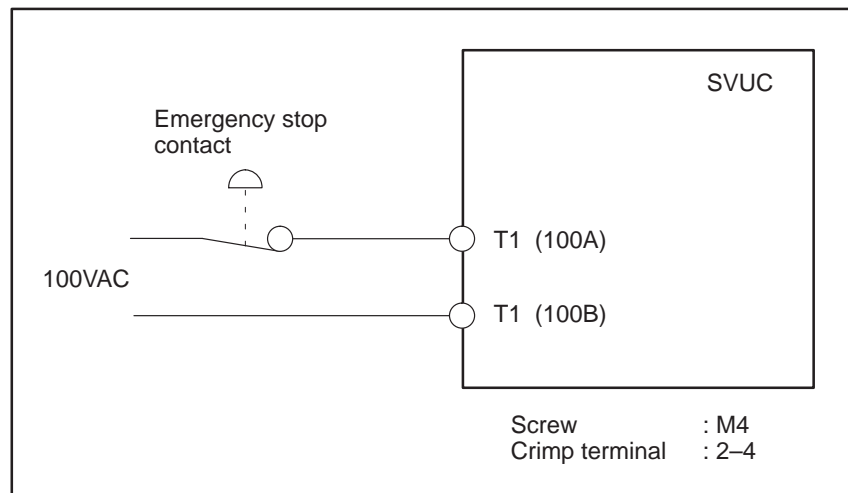

CAUTION

For the specifications of the single-phase input for emergency stop, see Section 3.1.

9.3.13 For installation of the Lightning Surge Protector

SVU : Requires the use of an external circuit breaker and lightning surge protector.

SVUC : Features a built-in lightning arrester in the same way as the C series amplifier, hence does not require an external circuit breaker or lightning surge protector.

(1) Installation method

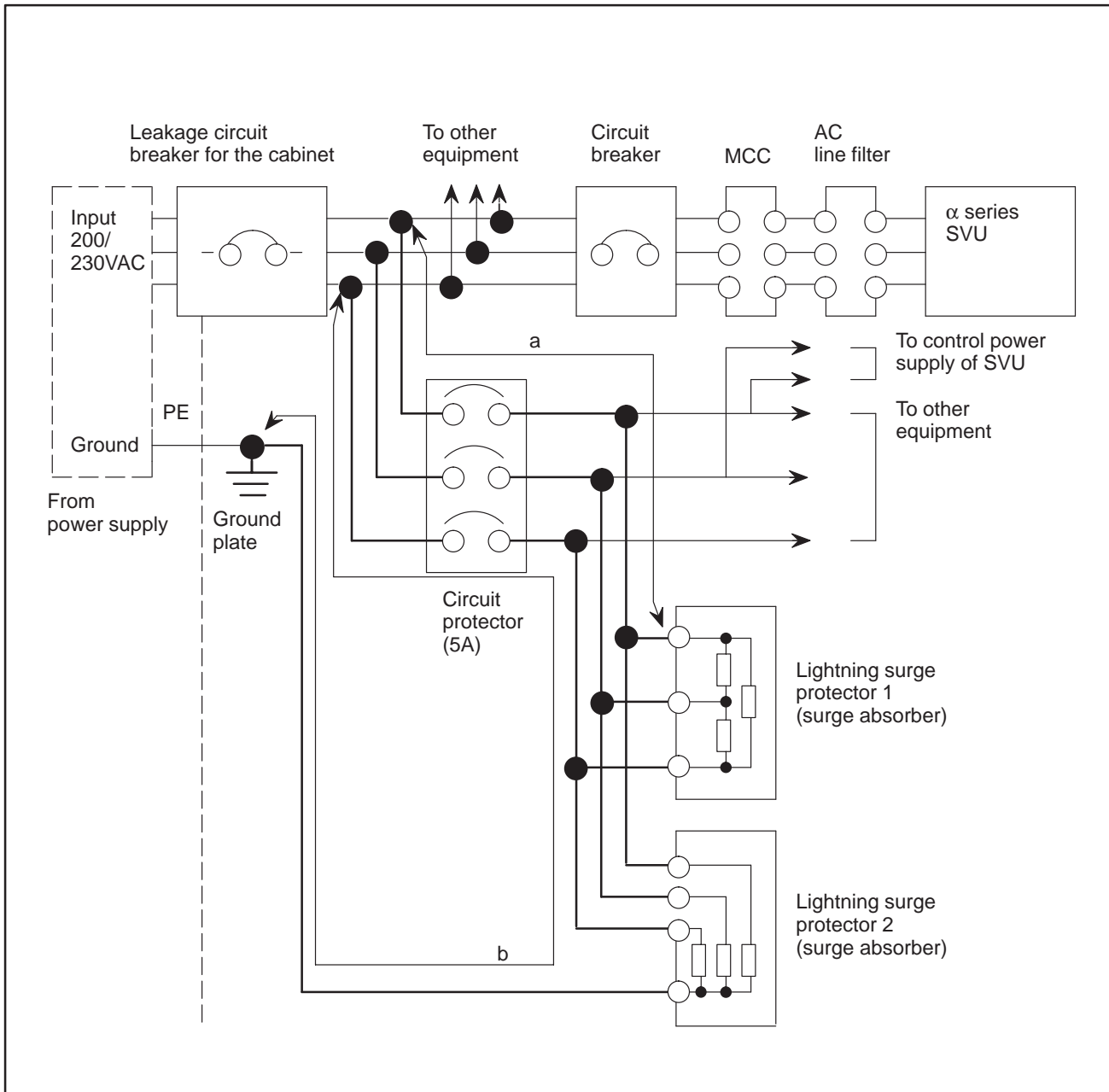

(2) Cautions

CAUTION

- 1 Minimize the length of wiring indicated in solid line so as to enhance the lightning surge absorptive effect.
 - Wire cross-sectional area :
2 mm² or more
 - Wire length :
The total length of the cable used for lightning surge protector 1 (a) and that used for lightning surge protector 2 (a) must not exceed 2 m.
- 2 When a dielectric strength test is conducted with an overvoltage (1000 or 1500 VAC) applied to the power line, previously remove the lightning surge protector 2; otherwise, it will operate on the supplied voltage.
- 3 The circuit protector (5A) is intended to protect the line if a lightning surge protector is short-circuited and fails to operate because of a surge voltage higher than its tolerance being applied.
- 4 Because usually no current flows through the lightning surge protectors 1 and 2, they can share the circuit protector (5A) with other equipment.
The circuit protector can be connected to the SVU control power supply and the fan motor power supply for the separate regenerative discharge unit.

(3) Examples of lightning surge protectors

Surge absorbers manufactured by Okaya Electric Industries Co., Ltd.

Lightning surge protector	Model	Clamp voltage (V) ±10%	Surge withstand current 8/20μs (A)	Surge withstand voltage 1.2/50μs (V)	Maximum allowable circuit voltage (Vrms)
1	R · A · V -781BYZ-2	783	1000	12K	300
2	R · A · V -781BXZ-2A	783	1000	12K	300

9.3.14 ESP Signal Connection for Use of Two or more SVUs or SVUCs

*) The connection of the ESP signal for the SVU differs from that for the SVUC.

(1) When using SVUs: Use CX4.

Up to six units can be connected. If more than six units must be connected, contact FANUC.

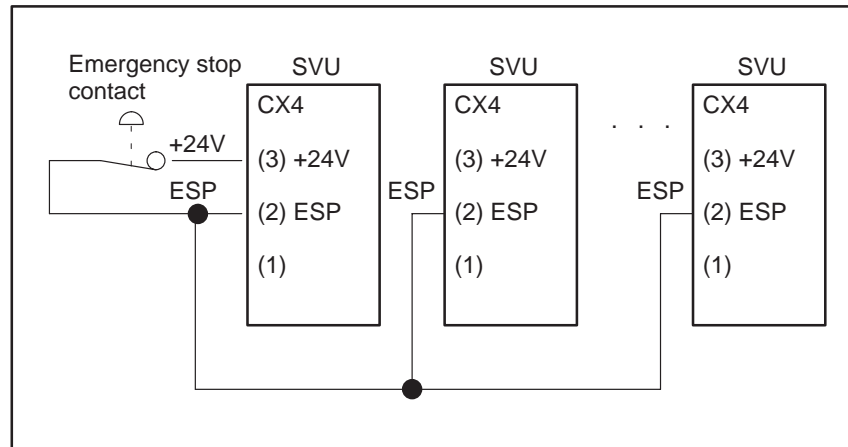

(2) When using SVUCs: Use terminal block T1 (100A, 100B).

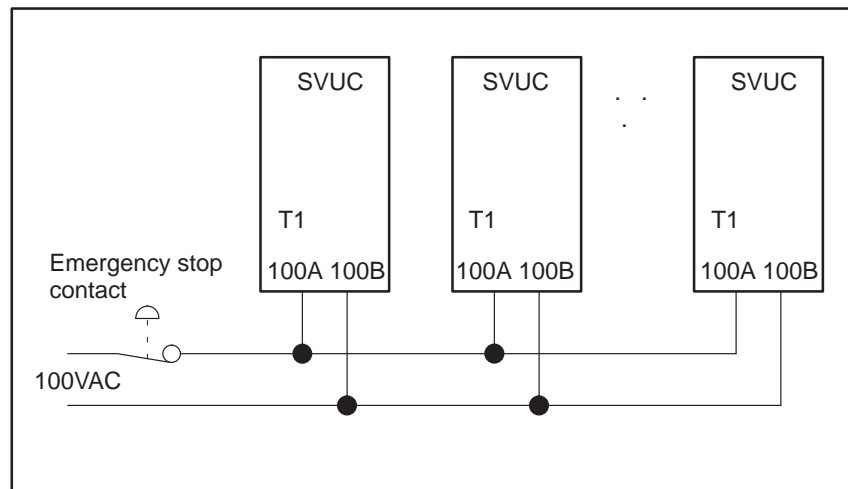

9.3.15 Monitoring Contact Output

Monitoring contacts RL1 and RL2, or RL2 and RL3, are used as the direct output of the auxiliary contact of a contactor or relay for a dynamic brake. Machine tool builders can use these contacts when designing a safety device or the like. The contacts correspond to MC1 and MC2 of a C series amplifier. The output from the contacts of some models differs from that of the C series amplifier.

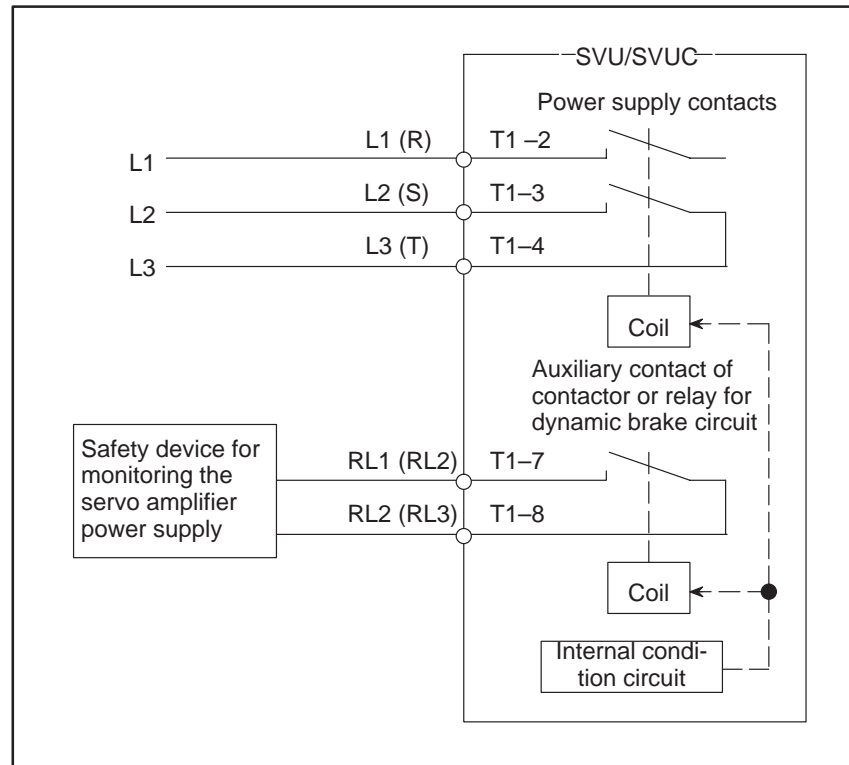

Table 9.3.15 MCC Monitoring Contact

	Auxiliary contact (while the power supply is shut off)	Terminal block	Signal name
C series amplifier	b contact (closed)	T1 (7-8)	MC1-MC2
SVUs and SVUCs except SVU1-130 or SVUC1-130	b contact (closed)	T1 (7-8)	RL1-RL2
SVU1-130, SVUC1-130	a contact (open)	T1 (7-8)	RL2-RL3

For details of the contact ratings, see Chapter 3, "Specification."

10

COMPATIBILITY WITH THE C SERIES SERVO AMPLIFIER

10.1 COMPARISON BETWEEN SVU/SVUC AND C SERIES AMPLIFIER

Table 10.1 Comparison between SVU/SVUC and C series Amplifier

Item	SVUC	SVU
External shape and mounting provisions	Same as C series amplifier	Same as C series amplifier
① NC interface	TYPE A interface TYPE B interface	Type A interface Type B interface
② Emergency stop interface	Same as C series amplifier (100 VAC)	24 VDC (connector CX4)
③ Surge absorber for input protection	Same as C series amplifier	Not provided (An external device is required.)
④ MCC monitoring contact	a-contact output for SVUC1-130 only	a-contact output for SVU1-130 only
TUV	Non-compliant	Fully compliant
UL/CSA	Fully compliant	Fully compliant
Wiring, cable	Same as C series amplifier	Same as C series amplifier, except for emergency stop interface
⑤ Connector positions	Almost same as C series amplifier	Almost same as C series amplifier
Terminal block positions	Same as C series amplifier	Same as C series amplifier
Combination with an S series motor	Possible	Impossible
⑥ Power shut-off method	Two-phase shut-off	Two-phase shut-off

① NC interface

This unit supports both the TYPE B interface and the TYPE A interface, only the latter being featured by the C series amplifier.

The C series amplifier uses connectors CN1(L) and CN1M for the TYPE A interface. The corresponding connectors on the SVU/SVUC are JV1B and JV2B.

② ESP interface

SVU: Uses 24 VDC in the amplifier. The power connection is made using a connector, not a terminal block.

SVUC: Uses 100 VAC, in the same way as the C series amplifier.

Model	Signal	Terminal	Signal name
C series amplifier	1φ 100 VAC	T1 (5-6)	100A - 100B
SVU	24 VDC	CX4 (2-3)	ESP - +24
SVUC	1φ 100 VAC	T1 (5-6)	100A - 100B

③ Surge absorber

SVU: Does not have a built-in surge absorber, so as to conform to European standards. An external surge absorber is required. For details, see Subsec. 9.3.13.

SVUC: Contains a surge absorber in the same way as the C series amplifier. An external surge absorber is not required.

④ The specifications of the monitoring contact have been partly modified.

The monitoring contacts of the C series amplifier provide the output for the auxiliary contact of the magnetic contactor used to shut off the main circuit. The monitoring contacts of the SVU/SVUC provide the output for the auxiliary contact of a DB relay or contactor. For details, see Subsec. 9.3.15.

⑤ Connector positions

The SVU/SVUC has connectors for both the TYPE-B interface and the conventional TYPE-A interface.

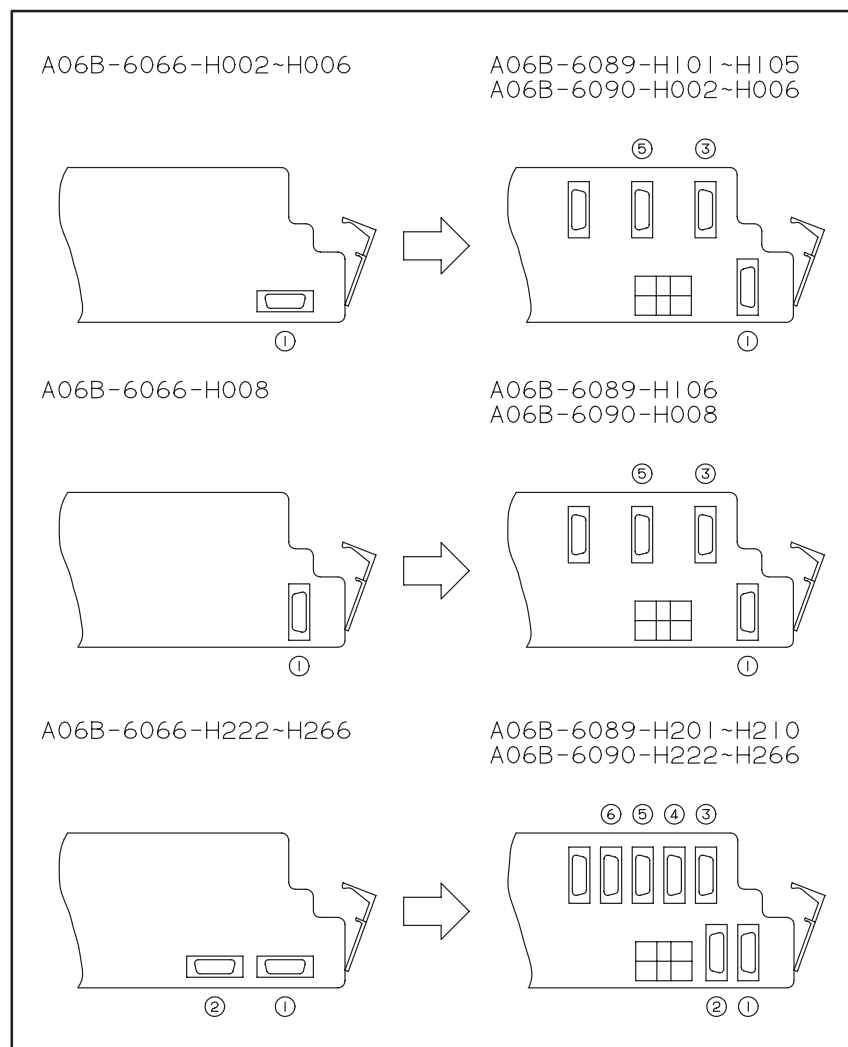

	Name	Interface	Connector name	
			C series amplifier	SVU/SVUC
①	NC interface connector: L-axis	TYPE A	CN1 (L)	JV1B
②	NC interface connector: M-axis	TYPE A	CN1M	JV2B
③	NC interface connector: L-axis	TYPE B	—————	JS1B
⑤	NC interface connector: M-axis	TYPE B	—————	JS2B
⑤	Connector for pulse coder connection: L-axis	TYPE B	—————	JF1
⑥	Connector for pulse coder connection: M-axis	TYPE B	—————	JF2

NOTE
 For details of the SVU/SVUC connectors, see Subsec. 9.2.3.

⑥ Power shut-off

The C series amplifier shuts off all three phases of the input by means of the internal magnetic contactor. The SVU/SVUC, however, shuts off only two phases using the internal power relay. This two-phase shut-off enables effective shut-off of the power. If three-phase shut-off (complete separation of the potential) is necessary, use an externally mounted MCC.

NOTE
 To gain approval to affix the CE marking (machinery directive), an external MCC satisfying European safety requirements is necessary. For details, see Subsec. 9.1.2.

10.2

NOTES ON REPLACING A C SERIES AMPLIFIER WITH THE SVUC

- (1) Switch setting
Some switches have been added on the front of the amplifier. The following switches must be set:
 - Interface setting (SW1)
 - SVU/SVUC mode setting (SW2)
 - Protection setting for regenerative discharge resistor (SW3, SW4)Set these switches as described in Section 3.4.
- (2) MCC monitoring contact output
The conventional b–contact output has been changed to the a–contact output in the case of the SVUC1–130 only. For details, see Subsec. 9.3.15.
- (3) Cable and connector
The connector names of the α series are the same as those of the NC, but different from those of the C series amplifier. JV1B and JV2B of the SVUC correspond to CN1(L) and CN1M of the C series amplifier.
- (4) Maintenance fuse
The maintenance fuse of the C series amplifier cannot be used with the SVUC because of a difference in ratings. As the SVUC maintenance fuse, designate A06B–6089–K250.
 - C series amplifier maintenance fuse
 - Control power fuse (HM32 fuse) : A06B–6066–K207
 - Fan motor fuse (for H008, P405H fuse) : A06B–6066–K208
 - SVUC maintenance fuse (HM32 fuse)
 - Control power fuse (HM32 fuse) : A06B–6089–K250
 - Fan motor fuse (for H008, HM32 fuse) : A06B–6089–K250
- (5) Connector positions
Connectors are provided for the TYPE A and TYPE B interfaces. For details, see Section 10.1.
- (6) Separate regenerative discharge resistor
A06B–6089–H*** has been modified from A06B–6066–H*** such that it complies with VDE 0160. Their specifications (characteristics and external dimensions) are, however, the same. A06B–6066–H*** can, therefore, be used in place of A06B–6089–H***.

NOTE

A06B–6066–H*** does not comply with VDE 0160.

[A]

AC Line Filter, 45
 AC Line Filter, 19
 AC Line Filter and Separate Regenerative Discharge Unit, 18
 Altitude, 35
 Ambient Temperature, 35
 Atmosphere, 35

[B]

Basic connection, 57
 Battery Case, 51

[C]

Calculating the Amount of Regenerative Discharge, 22
 Capacity of Three-phase Power Supply, 27
 Cautions for Installation, 36
 Circuit breaker and magnetic contactor, 31
 Comparison between SVU/SVUC and C series Amplifier, 99
 Compatibility with the C Series Servo Amplifier, 99
 Connection, 56
 Connection Example for SVU, 57
 Connection Example for SVUC, 61
 Connector and Terminal (T1) , 63

[D]

Detailed connection, 65
 Detailed Connection of Cable K1, 65
 Detailed Connection of Cable K10 , 92
 Detailed Connection of Cable K11, 93
 Detailed Connection of Cable K12, 94
 Detailed Connection of Cable K2, 70
 Detailed Connection of Cable K3, 77
 Detailed Connection of Cable K4, 79
 Detailed Connection of Cable K5, 87
 Detailed Connection of Cable K6, 88
 Detailed Connection of Cable K7, 88
 Detailed Connection of Cable K8, 89
 Detailed Connection of Cable K9, 91

[E]

Environmental Conditions, 35
 ESP Signal Connection for Use of Two or more SVUs or SVUCs, 97

[F]

For installation of the Lightning Surge Protector, 95

[G]

Ground, 39

[H]

Heat Generation, 32
 How to Select a Ground Fault Interrupter, 37
 How to Select a Transformer, 30
 Humidity, 35

[I]

Input power supply, 26
 Installation Conditions and Cautions, 35
 Interface with the NC, 56

[M]

Measures for Noise, 38
 Monitoring Contact Output, 98

[N]

Normal Operation Mode, 14
 Notes on Replacing a C series Amplifier with the SVUC, 102

[O]

Othes, 5
 Outline Drawings and Area of Maintenance, 41
 Outline drawings and area of maintenance, 41

[P]

Panel cutout drawing, 52

Power Requirements, 27
Power Supply, 25
Power Transformer for Export, 47
Power Transformers for Exports, 29
Protection and Error Detection Function, 12

[R]

Regenerative Discharge Capacity of Regenerative Discharge Resistor (Built-in and Separate Types), 24

[S]

Safety Standards, 56
Separate Regenerative Discharge Unit, 21, 48, 54
Servo Amplifier Unit, 41, 52

Signal Line Separation, 38
Single-phase Input for Control Circuit, 28
Specification, 8, 9, 29
SVU Grounding for CE Marking (EC Machinery Directive), 40
SVU Types, 3
SVUC Types, 4
Switch Setting, 15

[T]

Type of Unit and Designation, 3

[V]

Vibration, 35

Revision Record

FANUC CONTROL MOTOR AMPLIFIER α series (SERVO AMPLIFIER UNIT) DESCRIPTIONS (B-65192EN)

02	Jun., '96	Section "Safety Precautions" has been added. Some descriptions relating to the SVUC have been added.			
01	Feb., '95	_____			
Revision	Date	Contents	Revision	Date	Contents

Alpha Series Control Motor Amplifier

Servo Amplifier Unit SVU3

Descriptions Manual, B-65192EN/02-01



GE Fanuc Automation

Computer Numerical Control Products

*Alpha Series Control Motor Amplifier
Servo Amplifier Unit SVU3*

Descriptions Manual

B-65192EN/02-01

June 1996

Warnings and notices for this publication

GFLE-003

Warning

In this manual we have tried as much as possible to describe all the various matters. However, we cannot describe all the matters which must not be done, or which cannot be done, because there are so many possibilities.

Therefore, matters which are not especially described as possible in this manual should be regarded as "impossible".

Notice

This document is based on information available at the time of its publication. While efforts have been made to be accurate, the information contained herein does not purport to cover all details or variations in hardware or software or to provide every contingency in connection with installation, operation, or maintenance. Features may be described herein which are not present in all hardware and software systems. GE Fanuc Automation assumes no obligation of notice to holders of this document with respect to changes subsequently made.

GE Fanuc Automation makes no representation or warranty, expressed, implied, or statutory with respect to, and assumes no responsibility for accuracy, completeness, sufficiency, or usefulness of the information contained herein. No warranties of merchantability or fitness for purpose shall apply.

The following are Registered Trademarks of GE Fanuc Automation

CIMPLICITY® Genius®

The following are Trademarks of GE Fanuc Automation

Alarm Master	PROMACRO
CIMSTAR	Series Five
Field Control	Series 90
Genet	Series One
Helpmate	Series Six
LogicMaster	Series Three
Modelmaster	VuMaster
PowerMotion	Workmaster
ProLoop	

© Copyright 1998 FANUC Ltd

Authorized Reproduction GE Fanuc Automation Europe S.A.

All Rights Reserved

No part of this manual may be reproduced in any form.
All specifications and designs are subject to change without notice.

CONTENTS

1. OVERVIEW	1
2. CONFIGURATION	2
2.1 Type of Unit and Designation	3
3. SPECIFICATION	4
3. 1 Specification	4
3. 2 Protection and Error Detection Function	5
3. 3 Normal Operation Mode	6
3. 2 Switch Setting	6
4. AC LINE FILTER AND SEPARATE REGENERATIVE DISCHARGE UNIT	8
4. 1 AC Line Filter	8
4. 2 Separate Regenerative Discharge Unit	8
5. POWER SUPPLY	10
5. 1 Input Power Supply	10
5. 2 Power Requirements	10
5. 3 Power Transformers for Exports	10
6. HEAT GENERATION	11
7. INSTALLATION CONDITIONS AND CAUTIONS	12
7. 1 Environmental Conditions	12
7. 2 How to select a Group Fault Interrupter	12
7. 3 Measures for Noise	12
7. 3. 1 Signal line separation	12
7. 3. 2 Ground	12
7. 3. 3 Connection of ground cable of motor(for CE marking)	12
8. OUTLINE DRAWINGS AND AREA OF MAINTENANCE	13

9. CONNECTION	14
9. 1 Overview	14
9. 1. 1 Interface with the NC	14
9. 1. 2 Safety Standards	14
9. 2 Basic Connection	15
9. 2. 1 Interface TYPE-B without the external MCC	15
9. 2. 2 Interface TYPE-B with the external MCC	16
9. 2. 3 Connector and terminal(T1)	18
9. 3 Detailed connection	20
9. 3. 1 Detailed connection of cable K1	20
9. 3. 2 Detailed connection of cable K2	20
9. 3. 3 Detailed connection of cable K3	20
9. 3. 4 Detailed connection of cable K4	20
9. 3. 5 Detailed connection of cable K5	20
9. 3. 6 Detailed connection of cable K6	20
9. 3. 7 Detailed connection of cable K7	20
9. 3. 8 Detailed connection of cable K8	20
9. 3. 9 Detailed connection of cable K9	20
9. 3. 10 Detailed connection of cable K10	21
9. 3. 11 Detailed connection of cable K11	21
9. 3. 12 For installation of the Lightning Surge Protector	21
9. 3. 13 ESP signal connection for use of two or more SVUs	21
APPENDIX Check Pin Board	22
Overview	22
Connection to the Servo Amplifier Unit	23

1 OVERVIEW

The FANUC α SERIES CONTROL AMPLIFIER UNIT is suitable for system with three feed axes.

The features of the servo amplifier unit are as follows :

(1) Compact

The servo amplifier unit is integrated with a power supply.

It enables implementation of a compact system with three feed axes.

(2) Satisfies Safety Standards

The servo amplifier unit is designed to comply with the VDE0160(Europe), UL(USA), and CSA(Canada) safety standards.

(3) New interfacing capability

The servo amplifier unit provides a new interface(TYPE-B) for the CNC.

(The conventional interface(TYPE-A) is not provided.)

(4) Up-to-date power device

The servo amplifier unit uses an up-to-date power device, IPM (Intelligent Power Module), to reduce power loss and enhance alarm detection, thereby increasing its reliability.

Note

When you see this description, please refer to α SERIES SERVO AMPLIFIER UNIT (SVU) DESCRIPTIONS (B-65192EN).

2 CONFIGURATION

Fig.2 is the configuration of a NC system with three controlled axes. A separate regenerative discharge unit may be required in applications in which the regenerative energy is high.

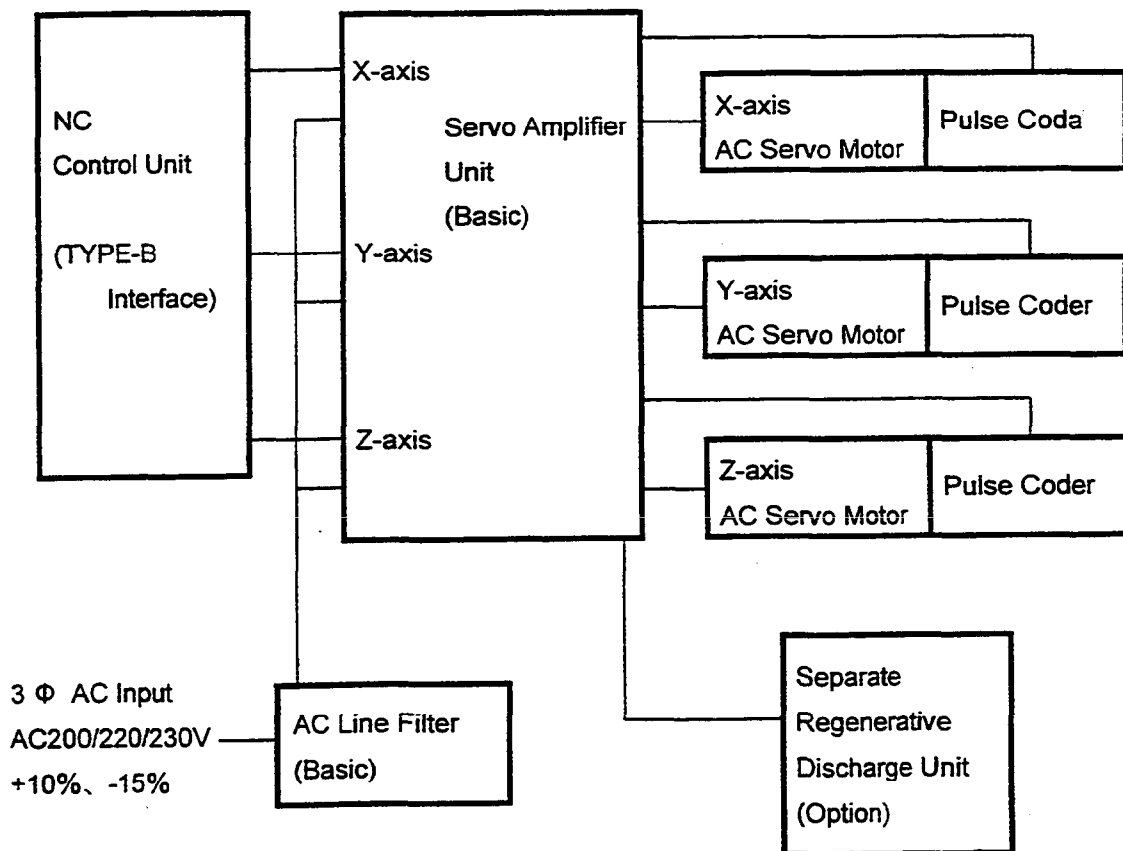

Fig.2 Example of configuration

2.1 Type of Unit and Designation

Table 2.1.1(a) Type of Unit and Designation

Group	Axis	Name	Designation	Applied motor group		
				L-axis	M-axis	N-axis
Basic	3	SVU3-12/12/12	A06B-6089-H321	Group A	Group A	Group A
		SVU3-12/12/20	A06B-6089-H322	Group A	Group A	Group B
		SVU3-12/20/20	A06B-6089-H323	Group A	Group B	Group B
		SVU3-20/20/20	A06B-6089-H324	Group B	Group B	Group B

Name of Servo Amplifier

SVU3-□/□/□

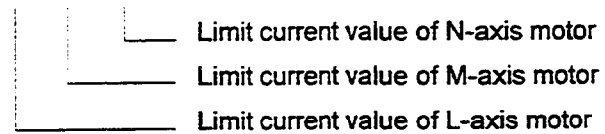

Table 2.1.1(b) Type of Unit and Designation

Applied motor group	AC Servo Motor
Group A	α 0.5/3000, α 1/3000, α 2/2000, α 2/3000, β 1/3000, β 2/3000, α E1/3000, α E2/3000
Group B	α C3/2000, α C6/2000, α C12/2000, β 3/3000, β 6/3000, α E6/2000

Note

Refer to B-65192 2.1 Type of Unit and Designation to pick up following items.

- AC Line Filter
- Power Transformer for export
- Separate Regenerative Discharge Unit
- Connector
- Fuse
- Battery
- Breaker
- Lightning Surge Protector

3 SPECIFICATION

3.1 Specification

Table 3.1 Specification (Each model)

Axis	Name	Designation	L-axis		M-axis		N-axis	
			Rated current [Arms]	Current limit [Apeak]	Rated current [Arms]	Current limit [Apeak]	Rated current [Arms]	Current limit [Apeak]
3	SVU3-12/12/12	A06B-6089-H321	3.0	12	3.0	12	3.0	12
	SVU3-12/12/20	A06B-6089-H322	3.0	12	3.0	12	5.9	20
	SVU3-12/20/20	A06B-6089-H323	3.0	12	5.9	20	5.9	20
	SVU3-20/20/20	A06B-6089-H324	5.9	20	5.9	20	5.9	20

(Note 1) The rated output is guaranteed under the rated input voltage. When the input voltage fluctuates, the rated output may not be obtained even if the fluctuation is within the tolerance.

(Note 2) The current limit are those typical. The operating value may vary by about $\pm 10\%$ due to varying circuit parameters.

Note

Refer to B-65192 3.1 Specification to pick up following items.

- Power supply
- Control of main circuit
- Alarm and protection functions

3.2 Protection and Error Detection Function

The servo amplifier has protections and error detection functions. The detected alarm conditions are indicated by 7-segment LED on the front of the servo amplifier.

If an alarm occurs, the motor is forced to stop by a dynamic brake.

Table 3.2 Protection and Error Detection Function

Type	LED indication	Description
L-axis over-current alarm (HCL)	8	An abnormally high current flows in the L-axis motor.
M-axis over-current alarm (HCM)	9	An abnormally high current flows in the M-axis motor.
N-axis over-current alarm (HCN)	A	An abnormally high current flows in the N-axis motor.
L-,M-axis over-current alarm (HCLM)	b	An abnormally high current flows in the L- and M-axis motor.
M-,N-axis over current alarm (HCMN)	C	An abnormally high current flows in the M- and N-axis motor.
N-,L-axis over current alarm (HCNL)	d	An abnormally high current flows in the N- and L-axis motor.
L-,M-,N-axis over current alarm (HCLMN)	E	An abnormally high current flows in the L-,M- and N-axis motor.
L-axis IPM alarm (IPML)	8.	An error was detected by the IPM of L-axis. (Note 1)
M-axis IPM alarm (IPMM)	9.	An error was detected by the IPM of M-axis. (Note 1)
N-axis IPM alarm (IPMN)	A.	An error was detected by the IPM of N-axis. (Note 1)
L-,M-axis IPM alarm (IPMLM)	b.	An error was detected by the IPM of L- and M-axis. (Note 1)
M-,N-axis IPM alarm (IPMMN)	C.	An error was detected by the IPM of M- and N-axis. (Note 1)
N-,L-axis IPM alarm (IPMNL)	d.	An error was detected by the IPM of N- and L-axis. (Note 1)
L-,M-,N-axis IPM alarm (IPMLMN)	E.	An error was detected by the IPM of L-,M- and N-axis. (Note 1)

(Note 1) The IPM(Intelligent Power Module) can detect the following alarms.

- Over-current
- Over-heat
- Drop in IPM control power voltage

(Note 2) When the control power is separated from the main power, low DC link voltage alarm(LVDC) is detected if the circuit breaker for the servo amplifier is off.

Note

Refer to B-65192 3.2 Protection and Error Detection Function to pick up following items.

- Over-voltage alarm(HV)
- Low control power voltage alarm(LV)
- Low DC link voltage alarm(LVDC)
- Regenerative discharge control circuit failure alarm(DCSW)
- Over-regenerative discharge alarm(DCOH)
- Dynamic brake circuit failure alarm(DBRLY)

3.3 Normal Operation Mode

Refer to B-65192 3.3 Normal Operation Mode.

3.4 Switch Setting

There are four channel switches above the 7-segment LED behind the terminal board cover on the front of the servo amplifier. These switches should be set as described below before use of the servo amplifier.

(1)Positions

Refer to B-65192 3.4 Switch setting.

(2)Switch-1 and -2 setting

Set Switch-1 and -2 to OFF.

If the setting is incorrect, VRDY OFF alarm occurs.

(3)Switch-3 and -4 setting

The setting varies depending on the regenerative discharge resistor used.

If the setting is incorrect, the regenerative discharge control circuit failure alarm(DCSW) cannot be detected correctly.

Table 3.4 Switch-3 and -4 setting

Switch-3	Switch-4	Regenerative Discharge Resistor
ON	ON	Built-in
ON	OFF	Separate A06B-6089-H500
OFF	OFF	Separate A06B-6089-H713(800W), A06B-6089-H714(1200W)

4

AC LINE FILTER AND SEPARATE REGENERATIVE DISCHARGE UNIT

4.1 AC Line Filter

An AC line filter should be used to reduce the effect of harmonic noise to the power supply. If two or more servo amplifiers are connected to one AC line filter, the total continuous output rating of all connected servo amplifiers should be kept below the continuous output rating of the AC line filter. Estimation of total continuous output rating of the servo motors can be reduced depending on the load conditions.

Note

Refer to B-65192 4.1 AC Line Filter to pick up following items.

- Specification of AC Line Filter
- Continuous output rating of servo motors

4.2 Separate Regenerative Discharge Unit

If a servo motor releases a large amount of regenerative discharge, which exceeds the regenerative discharge capacity of the regenerative discharge resistor in the servo amplifier, it is necessary to use a separate regenerative discharge unit.

If the calculated motor regenerative discharge for each axis exceeds the regenerative discharge capacity of the regenerative discharge resistor in the servo amplifier, use a separate regenerative discharge unit.

If it exceeds also the regenerative discharge capacity of the regenerative discharge resistor in the separate regenerative discharge unit, contact FANUC and ask for information. (If a machine has a high holding torque on its vertical axis with no counter balance, a large amount of high regenerative discharge occurs when the load moves down along the vertical axis. In such a case, especially if the machine has a long stroke and the load descends rapidly, the amount of generated regenerative discharge may exceed the regenerative discharge capacity of the separate regenerative discharge unit.)

Note

- (1) About Calculating the amount of regenerative discharge:
Refer to B-65192 4.2.1 Calculating the amount of regenerative discharge.
- (2) The regenerative discharge capacity of the regenerative discharge resistor without the forced cooling fan motor can be increased by cooling the resistor with an external cooling fan.
About the relationships between the speed of cooling air flow and the regenerative discharge capacity:
Refer to Table 4.2.1.
- (3) The separate regenerative discharge units listed in Table 4.2.2 are developed for use with the α series servo amplifier units and designed to meet the requirements of the European standards. The separate regenerative discharge units for C series servo amplifier units can be used for the α series servo amplifier units. However, they have not been designed to meet the requirements of the European Standards.

Table 4.2.1 Regenerative discharge capacity of built-in type
discharge resistor

Servo amplifier	No wind	Wind velocity 2m/sec	Wind velocity 4m/sec
A06B-6089-H321~H324	R=100W	R=200W	R=300W

Table 4.2.2 Regenerative discharge capacity of separate
regenerative discharge unit

Separate regenerative discharge unit	
A06B-6089-H713(16 Ω)	Forced cooling fan motor is installed. R=800W
A06B-6089-H714(16 Ω)	Forced cooling fan motor is installed. R=1200W

5

POWER SUPPLY

5.1 Input Power Supply

Refer to B-65192 5.1 Input Power Supply.

5.2 Power Requirements

Refer to B-65192 5.2 Power Requirements.

Power requirements for control circuit of SVU3 is as follows.

Servo Amplifier	Capacity
A06B-6089-H321~H324	50VA

5.3 Power Transformers for Exports

Use a power transformer for an export when this servo amplifier unit is used at a site where the line voltage is other than 200/220/230VAC.

Refer to B-65192 5.3.1 Specification, 5.3.2 How to select a transformer to pick up following items.

- Specification of a transformer
- How to select a transformer

6

HEAT GENERATION

The heat generation of the servo amplifier unit is calculated by the values given from each servo amplifier and motor.

Refer to B-65192 6.HEAT GENERATION to pick up following items.

- Heat generation depending on the motor
- How to calculate a heat generation

Total heat generation of SVU3 is as follows.

Amplifier model	Total heat generation(W): a	Heat generation in the cabinet(W): b
SVU3-□/□/□	33.5	33.5

7

INSTALLATION CONDITIONS AND CAUTIONS

7.1 Environmental Conditions

Refer to B-65192 7.1 Environmental conditions.

7.2 How to select a Group Fault Interrupter

Refer to B-65192 7.2 How to select a Group Fault Interrupter.

7.3 Measures for Noise

7.3.1 Signal line separation

Separate the signal lines from the amplifier input power lines and motor power lines.

Refer to B-65192 7.3.1 Signal line separation to pick up following items.

- Types of cables
- How to measure the cables

7.3.2 Ground

Refer to B-65192 7.3.2 Ground.

7.3.3 Connection of ground cable of motor (for CE marking)

Refer to B-65192 7.3.3 CONNECTION OF CABLE OF MOTOR.

8

OUTLINE DRAWINGS AND AREA OF MAINTENANCE

Refer to B-65192 8. OUTLINE DRAWINGS AND AREA OF MAINTENANCE to pick up following items.

- AC line filter
- Power transformer for export
- Separate regenerative discharge unit(with panel cutout drawing)
- Battery case

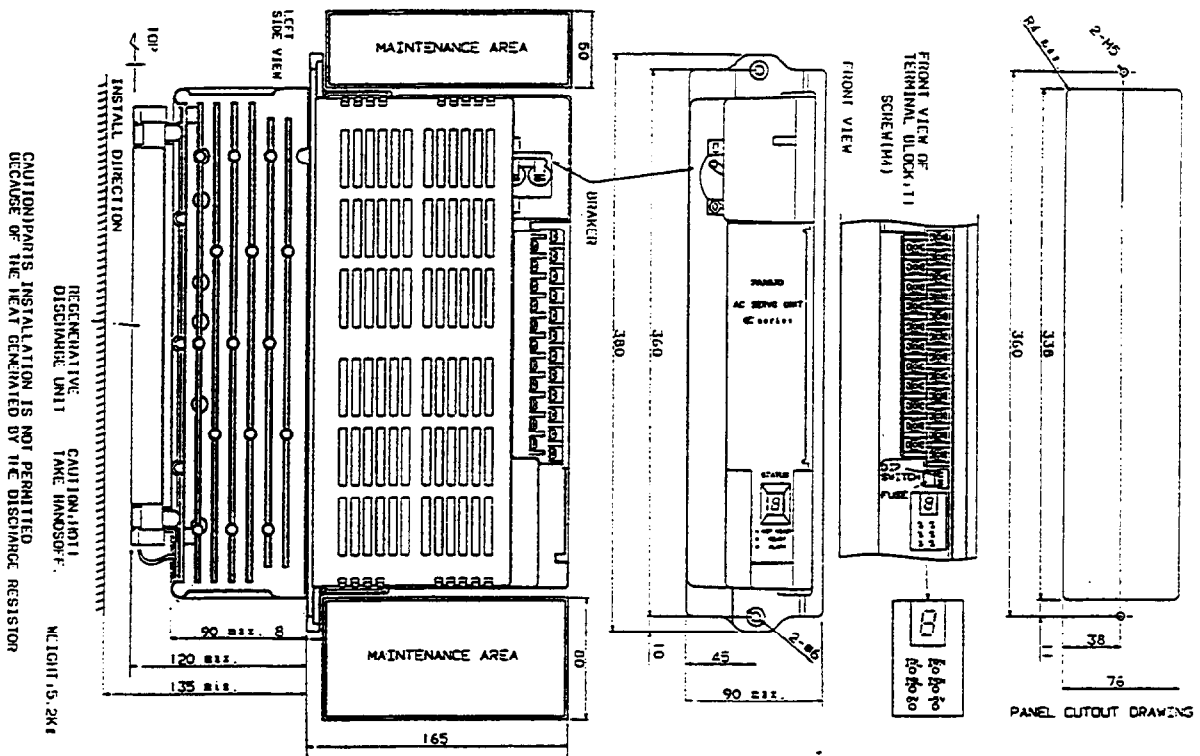

9 CONNECTION

9.1 Overview

9.1.1 Interface with the NC

This servo amplifier unit has only TYPE-B interface.

Interface type	NC
TYPE-B	Fanuc Series-16B,16C,18B,18C Fanuc Series-20,21TB,21GA Power Mate-H

9.1.2 Safety Standards

This servo amplifier unit is designed to comply with VDE0160, making it easy to design the machine with CE marking.

If the CE marking is required, the external MCC which shall be braked at ESP must be installed.

9.2 Basic Connection

9.2.1 Interface TYPE-B without the external MCC

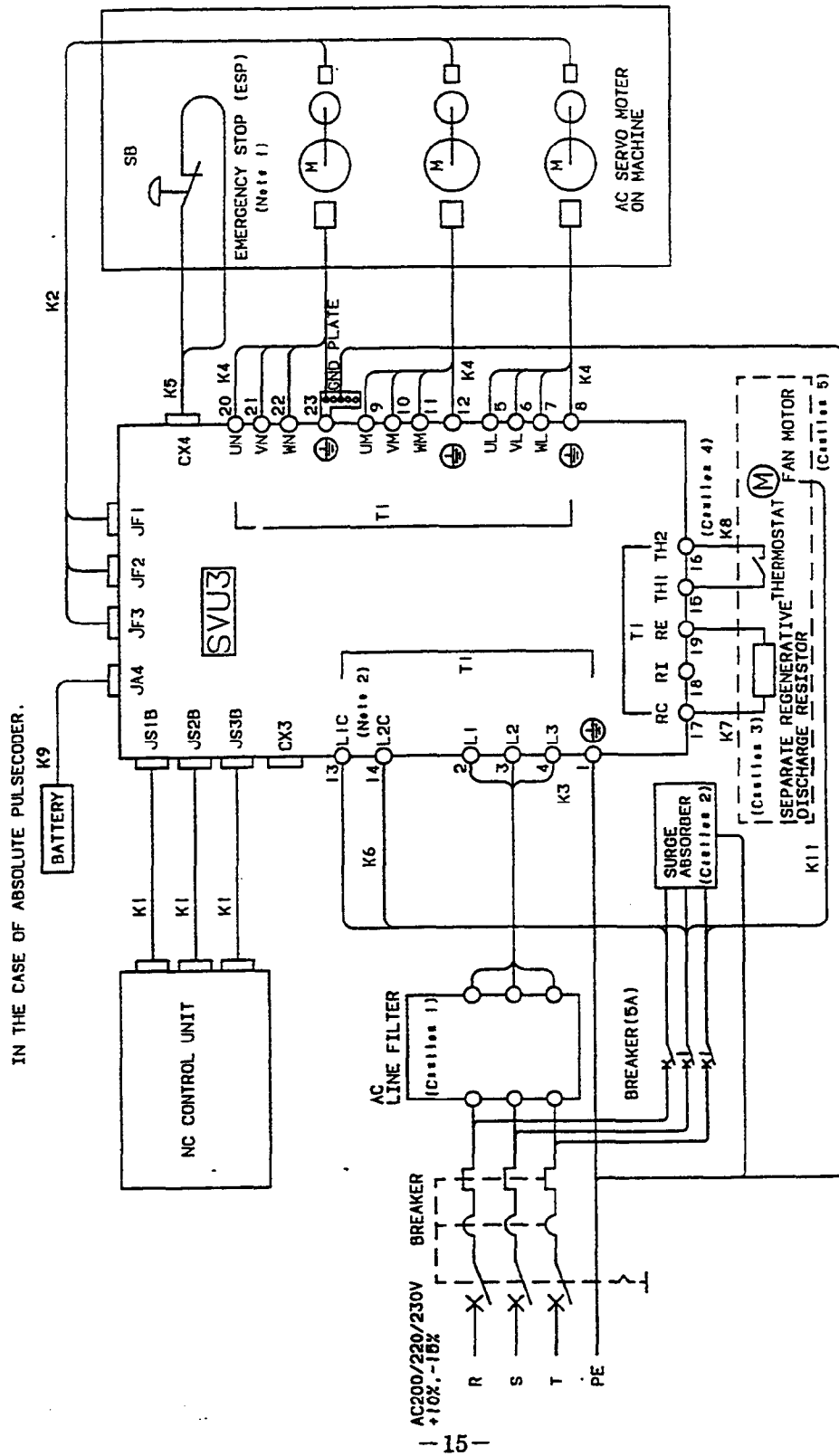

9.2.2 Interface TYPE-B with the external MCC

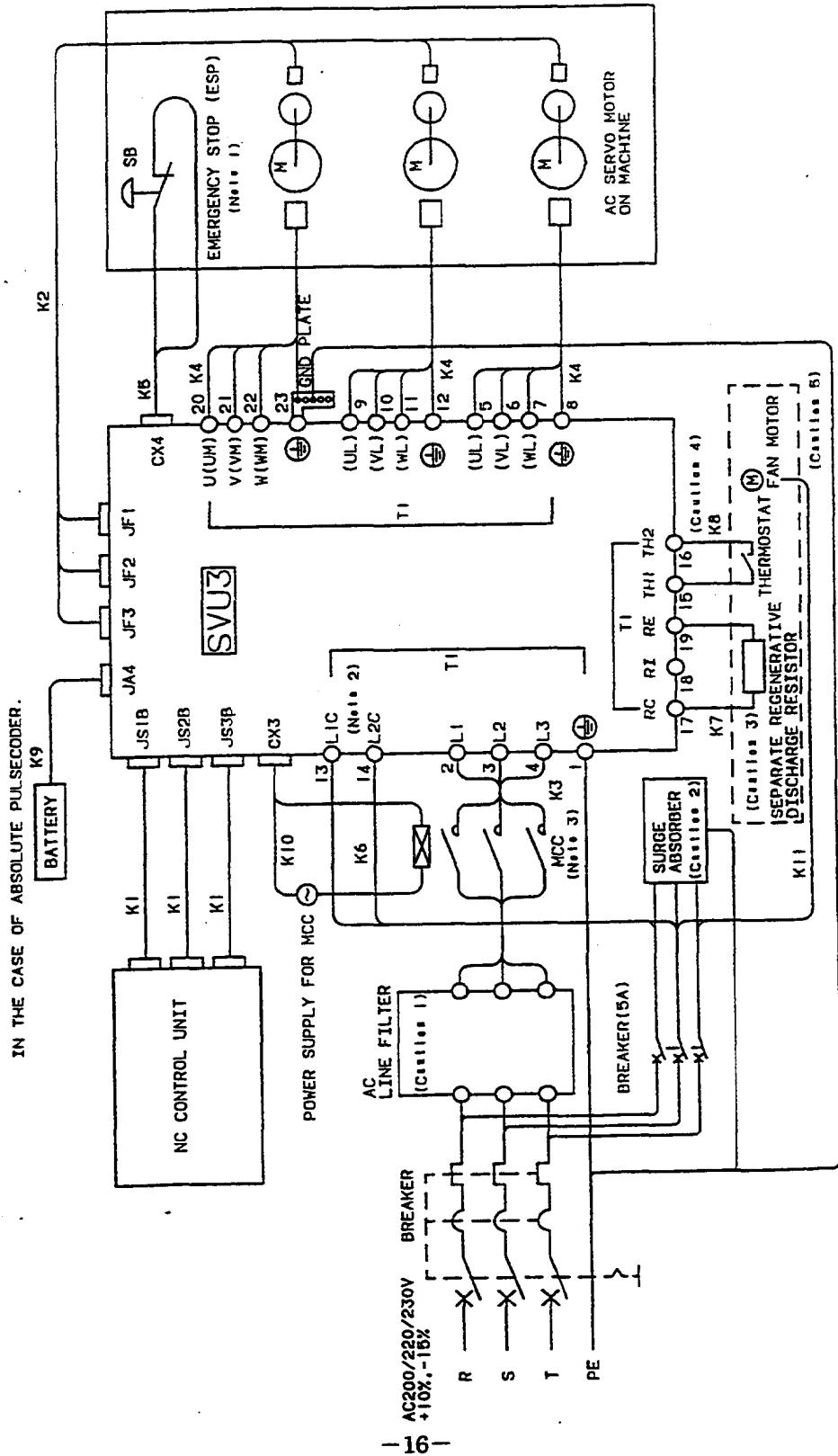

Caution

- (Caution 1) Be sure to use an AC line filter to reduce effect of harmonic noise to the power supply. Two or more amplifiers can be connected to one AC line filter if its power supply capacity is not exceeded.
- (Caution 2) This amplifier does not have a surge absorber inside. One should be installed externally.
- (Caution 3) RC and RI were connected with each other through a jumper bar at the factory. Remove the jumper bar, if a separate regenerative discharge unit is used.
- (Caution 4) TH1 and TH2 were connected with each other through a jumper bar at the factory. Remove the jumper bar, and connect them to the corresponding terminals of the separate regenerative discharge unit and power transformer.
- (Caution 5) Connect the fan motor to the circuit breaker(5A) is used if a separate regenerative discharge unit with a built-in fan motor.

Note



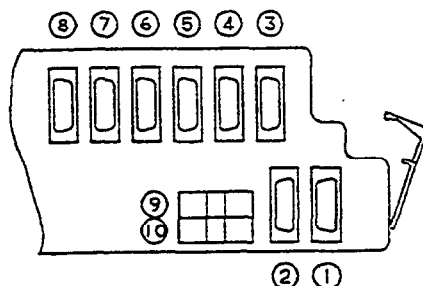

- (Note 1) This amplifier does not require 100VAC for an emergency stop.
- (Note 2) L1C and L1 were connected with each other through a jumper bar at the factory, and so were L2C and L2. Remove these jumper bars before connecting a power supply.
- (Note 3) Select a MCC that conforms to the European Standards.

9.2.3 Connector and terminal(T1)



	Name	Indication	Remarks
①	Connector for power supply of ABS Pulsecoder	JA4	
②	Connector for Check-pin board of amplifier	JX5	
③	Connector for NC Interface: L-axis	JS1B	TYPE-B Interface
④	Connector for NC Interface: M-axis	JS2B	TYPE-B Interface
⑤	Connector for NC Interface: N-axis	JS3B	TYPE-B Interface
⑥	Connector for Pulsecoder: L-axis	JF1	TYPE-B Interface
⑦	Connector for Pulsecoder: M-axis	JF2	TYPE-B Interface
⑧	Connector for Pulsecoder: N-axis	JF3	TYPE-B Interface
⑨	Connector for Main power supply (Y key)	CX3	1pin 3pin
⑩	Connector for ESP signal (X key)	CX4	2pin; ESP(at open) 3pin; 24V

T1

		1	
13	L1C	2	L1
14	L2C	3	L2
15	TH1	4	L3
16	TH2	5	UL
17	RC	6	V ₋
18	RI	7	WL
19	RE	8	
20	UN	9	UM
21	VN	10	VM
22	WN	11	WM
23		12	

9.3 Detailed connection

9.3.1 Detailed connection of cable K1

Refer to B-65192 9.3.1 Detailed connection of cable K1
(b) TYPE-B interface.

In case that JS3B:N-axis(third axis) is added at Connector name.

About wire material of cable of K1:

Refer to B-65192 Note) Wire material of cable of K1.

9.3.2 Detailed connection of cable K2

Refer to B-65192 9.3.2 Detailed connection of cable K2.

9.3.3 Detailed connection of cable K3

Refer to B-65192 9.3.3 Detailed connection of cable K3.

9.3.4 Detailed connection of cable K4

Refer to B-65192 9.3.4 Detailed connection of cable K4.

9.3.5 Detailed connection of cable K5

Refer to B-65192 9.3.5 Detailed connection of cable K5.

9.3.6 Detailed connection of cable K6

Refer to B-65192 9.3.6 Detailed connection of cable K6.

9.3.7 Detailed connection of cable K7

Refer to B-65192 9.3.7 Detailed connection of cable K7.

9.3.8 Detailed connection of cable K8

Refer to B-65192 9.3.8 Detailed connection of cable K8.

9.3.9 Detailed connection of cable K9

Refer to B-65192 9.3.9 Detailed connection of cable K9.

9.3.10 Detailed connection of cable K10

Refer to B-65192 9.3.10 Detailed connection of cable K10.

9.3.11 Detailed connection of cable K11

Refer to B-65192 9.3.11 Detailed connection of cable K11.

9.3.12 For installation of the Lightning Surge Protector

Refer to B-65192 9.3.12 For installation of the Lightning surge protector.

9.3.13 ESP signal connection for use of two or more SVUs

Refer to B-65192 9.3 Detailed connection

"ESP signal connection for use of two or more SVUs".

APPENDIX

Check Pin Board

Overview

When you are going to observe the signals inside the amplifier with an oscilloscope, attach the check pin board listed below to the connector(JX5).

Order No.	Description of the order	
A06B-6071-K290	Printed circuit board	A20B-1005-0340
	Cable(20cm)	A660-2042-T031#L200R0

Pin arrangement on the pin board

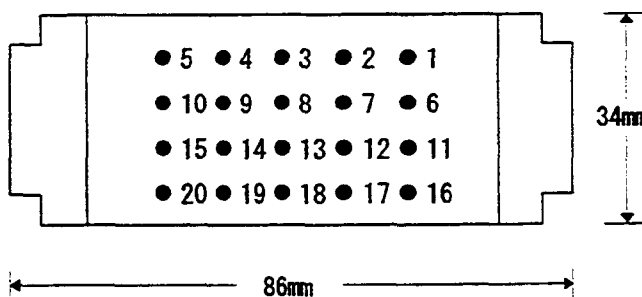

(Note 1) CN1 and CN2 are wired with a one-to-one correspondence.

(Note 2) The connector pin numbers correspond to the check pin numbers.

Connection to the Servo Amplifier Unit

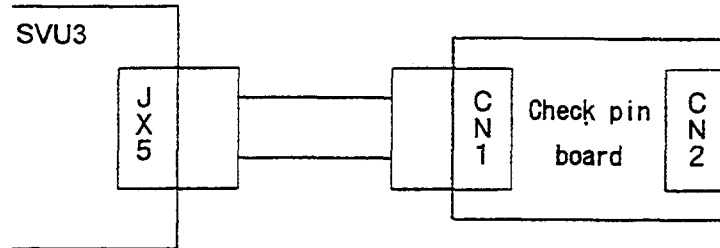

Pin No.	Signal name	Description
①		
②	0V	Reference voltage
③	IRL (Note 1)	L-axis R-phase motor current signal
④	ISL (Note 1)	L-axis S-phase motor current signal
⑤	IRM (Note 1)	M-axis R-phase motor current signal
⑥	ISM (Note 1)	M-axis S-phase motor current signal
⑦	IRN (Note 1)	N-axis R-phase motor current signal
⑧	ISN (Note 1)	N-axis S-phase motor current signal
⑨	0V	Reference voltage
⑩	0V	Reference voltage
⑪	24V	+24V power supply (with tolerance $\pm 5\%$)
⑫	15V	+15V power supply (with tolerance $\pm 5\%$)
⑬	-15V	-15V power supply (with tolerance $\pm 5\%$)
⑭	5V	+5V power supply (with tolerance $\pm 5\%$)
⑮		
⑯		
⑰		
⑱		
⑳		

(Note 1) The output voltage reflects directly the actual current in the motor.

To observe the output voltage, use an oscilloscope. The voltmeter position of a volt-ohm-millimeter or other voltmeters cannot be used.

Conversion of the motor current signal is as follows.

12A peak motor : 3 A/V

20A peak motor : 5 A/V

Alpha Series Control Motor Amplifier

Servo Amplifier Unit Model C (SVUC)

Descriptions Manual,



GE Fanuc Automation

Computer Numerical Control Products

*AlphaSeries Control Motor Amplifier
Servo Amplifier Unit Model C (SVUC)
Descriptions Manual*

Supplement to B-65192EN

This supplement contains information on the SVU Model C (SVUC) Amplifier. The SVUC is a direct replacement for the C Series amplifiers which are no longer available.

Specifically, it includes:

- Comparison of the SVU and SVUC amplifiers (see page 2).
- Ordering information for the SVUC (see page 3).
- Connection diagrams (see page 5).
- Outline drawings (see page 8).
- Maintenance (see page 12).

The SVUC uses an SVU with a 100V E-Stop circuit and internal MOVs for suppression to make it C-Series compatible.

The specification of SVUC amplifier

(Compare with SVU and C series)

1. Feature

a) Upper compatible with C series amplifier

SVUC is designed for the maintenance of C series amplifier .

And it is also used for the quick changing from C series amplifier.

As compare with SVU ,SVUC has more upper compatibility with C series amplifier.

- Inside surge absorber and breaker .
- Same interface of FSP (AC100V)

c) Not approved to CE mark

SVUC can't be approved to VDE0160(CE mark), because it has the inside surge absorber.

Note)However, SVUC can be approved to UL/ CSA.

We are now applying SVU and SVUC to UL/CSA.

c) Differences from SVU

The unit parts are same as SVU.

The control circuit board is same as SVU.

The power circuit board is

- P.W.B. is same as SVU.
- Some additional parts are located to SVU.

So the same equipment for C series amp. can be used for SVUC.

It is the reason that FANUC ask you the changing from C series to SVUC.

2. Compatibility to C series amplifier

	SVU(6089)	SVU C (6090)
Outline dimension	Same as C series	Same as C series
Interface of ESP	DC24V(AMP connector)	AC100V(same terminal)
Input surge absorber	External	Internal(same as C series)
Confirmation contact	In case of SVU1-130, b->a contact	In case of SVU11-130, b->a contact
CE mark	Approved(VDE0160)	Not approved(VDE0160)
ULCSA	Approved	Approved
Terminal and Connector	Almost same locations	Almost same locations
Connect to S motor	Impossible	Possible
Servo software	Same software for C series amp	Same software for C series amp
Axis board	Same board for C series amp	Same board for C series amp

The only difference point from C series amp is

- Confirmation contact of MCC of SVUC1-130 b-> a contact
(N.C. to N.O.)

3. Ordering number of SVUC

C series Amplifier can be replaced with SVUC.

(1) AMPLIFIER

C series Amplifier		α series Servo Amplifier Unit(SVUC)
A06B-6066-H002	⇒	SVUC1-4 A06B-6090-H002
A06B-6066-H003	⇒	SVUC1-12 A06B-6090-H003
A06B-6066-H004	⇒	SVUC1-40 A06B-6090-H004
A06B-6066-H006	⇒	SVUC1-80 A06B-6090-H006
A06B-6066-H008	⇒	SVUC1-130 A06B-6090-H008
A06B-6066-H222	⇒	SVUC1-4/4 A06B-6090-H222
A06B-6066-H223	⇒	SVUC1-4/12 A06B-6090-H223
A06B-6066-H224	⇒	SVUC1-4/40 A06B-6090-H224
A06B-6066-H233	⇒	SVUC1-12/12 A06B-6090-H233
A06B-6066-H234	⇒	SVUC1-12/40 A06B-6090-H234
A06B-6066-H236	⇒	SVUC1-12/80 A06B-6090-H236
A06B-6066-H244	⇒	SVUC1-40/40 A06B-6090-H244
A06B-6066-H246	⇒	SVUC1-40/80 A06B-6090-H246
A06B-6066-H266	⇒	SVUC1-80/80 A06B-6090-H266

(2) SEPARATE REGENERATIVE DISCHARGE UNIT

C series Amplifier		α series Servo Amplifier Unit(SVUC)
A06B-6066-H500	⇒	A06B-6089-H500
A06B-6066-H713	⇒	A06B-6089-H713
A06B-6066-H714	⇒	A06B-6089-H714
A06B-6066-H711	⇒	A06B-6089-H711
A06B-6066-H712	⇒	A06B-6089-H712

Cross-Reference of Catalog Numbers

Axis L *	Axis M *	Series SVU	Series C	SVUC
-	4	---	A06B-6066-H002	A06B-6090-H002
-	12	A06B-6089-H101	A06B-6066-H003	A06B-6090-H003
-	20	A06B-6089-H102	---	---
-	-	---	---	---
-	40	A06B-6089-H104	A06B-6066-H004	A06B-6090-H004
-	80	A06B-6089-H105	A06B-6066-H006	A06B-6090-H006
-	130	A06B-6089-H106	A06B-6066-H008	A06B-6090-H008
2	2	---	A06B-6066-H211	A06B-6090-H211
4	4	---	A06B-6066-H222	A06B-6090-H222
4	12	---	A06B-6066-H223	A06B-6090-H223
4	40	---	A06B-6066-H224	A06B-6090-H224
12	12	A06B-6089-H201	A06B-6066-H233	A06B-6090-H233
12	20	A06B-6089-H202	---	---
20	20	A06B-6089-H203	---	---
12	40	A06B-6089-H204	A06B-6066-H234	A06B-6090-H234
20	40	A06B-6089-H205	---	---
40	40	A06B-6089-H206	A06B-6066-H244	A06B-6090-H244
40	80	A06B-6089-H207	A06B-6066-H246	A06B-6090-H246
80	80	A06B-6089-H208	A06B-6066-H266	A06B-6090-H266
12	80	A06B-6089-H209	A06B-6066-H236	A06B-6090-H236
20	80	A06B-6089-H210	---	---

* L = 1st axis; M = 2nd axis.

Connection Diagram (Standard Connection - UL, CSA)

Connection of C Series

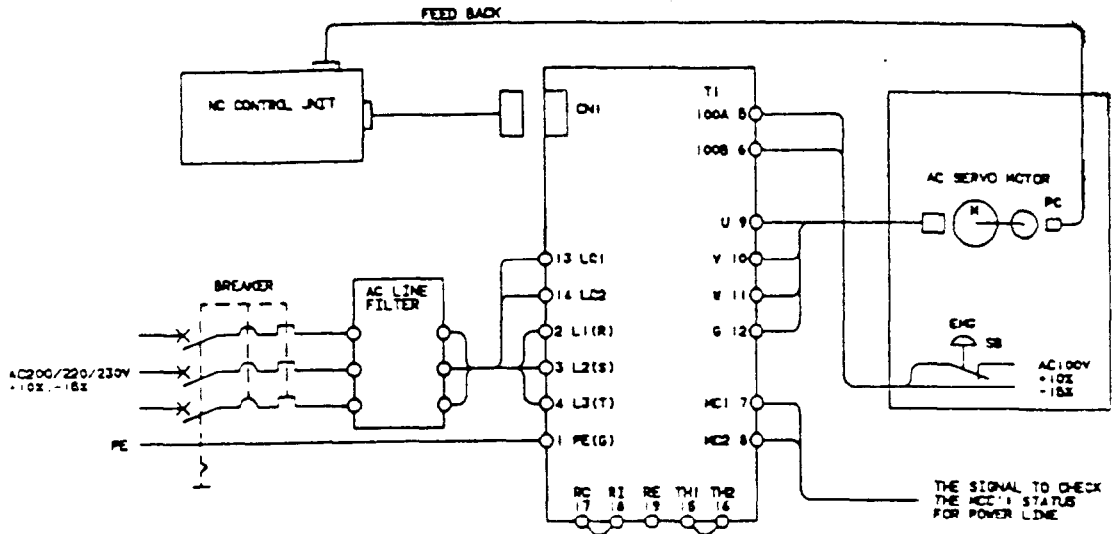

Connection of α SVUC Series

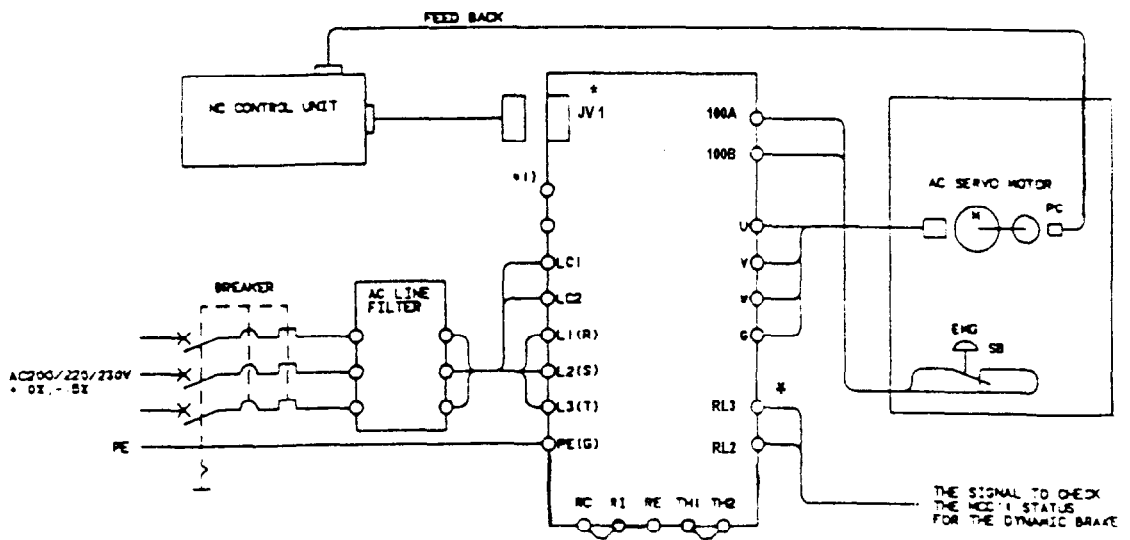

* Different from C series.

SVUC Series Servo Amplifier (Replacement for C Series)

General

Mounting, wiring, and rating of the SVUC series servo amplifier is the same as for the C series servo amplifier. The order number changes from A06B-~~6066~~-Hxxx to A06B-~~6090~~-Hxxx.

There are some additional connectors that were not on the C amp. They are located on the bottom and can be ignored. This is because both Type A (C series-style amplifier) and Type B (SVU-style amplifier) feedback interface, designated as JV and JS, respectively, are available. The JF and CX connectors of the standard SVU amplifier are also available but will not be used in a C series replacement application. There are also some DIP switches to be set, as indicated below.

Mounting

Mounting of the SVUC series servo amplifier is the same as for the C series servo amplifier.

Wiring

Wiring is the same as for the C series servo amplifier, as all terminal board points are duplicated. The only deviation is that the contact, which indicates that the MCC contactor is dropped out, is designated as RL2 and RL3, instead of MC1 and MC2. This is because the indication of power off to the motor is from the dynamic brake relay, instead of the MCC contactor. The actual status of the signal represents the same indication for the state of the amplifier.

The connector for the velocity command from the CNC is redesignated JV1, instead of CN1.

Setup

There are four DIP switches located above the status indicator, behind the terminal board cover. The position of these switches should be checked, as they were not on the C series amplifier. The switches are designated from 1 to 4, from the bottom up. The ON position of the switch is to the right. Switch 1 selects the type of interface to the CNC. For a C replacement, it will always be Type A, and the switch will be set to the left to OFF. Switch 2 is always set to the left to OFF. Switches 3 and 4 indicate the discharge resistor used with the SVUC, as follows:

Switch 3	Switch 4	Discharge Resistor Type
ON	ON	Internal resistor of SVUC.
ON	OFF	100 watt separate resistor for SVUC-12 or SVUC-20. 200-watt separate resistor for SVUC-40 or SVUC-80.
OFF	OFF	200-watt separate resistor for SVUC-12 or SVUC-20 800 or 1200 watt separate resistor for SVUC-40 or SVUC-80.

5 OUTLINE DRAWINGS AND AREA OF MAINTENANCE
 1 Outline drawings and area of maintenance
 1.1 Servo amplifier unit
 (a) SVUG1-4.12

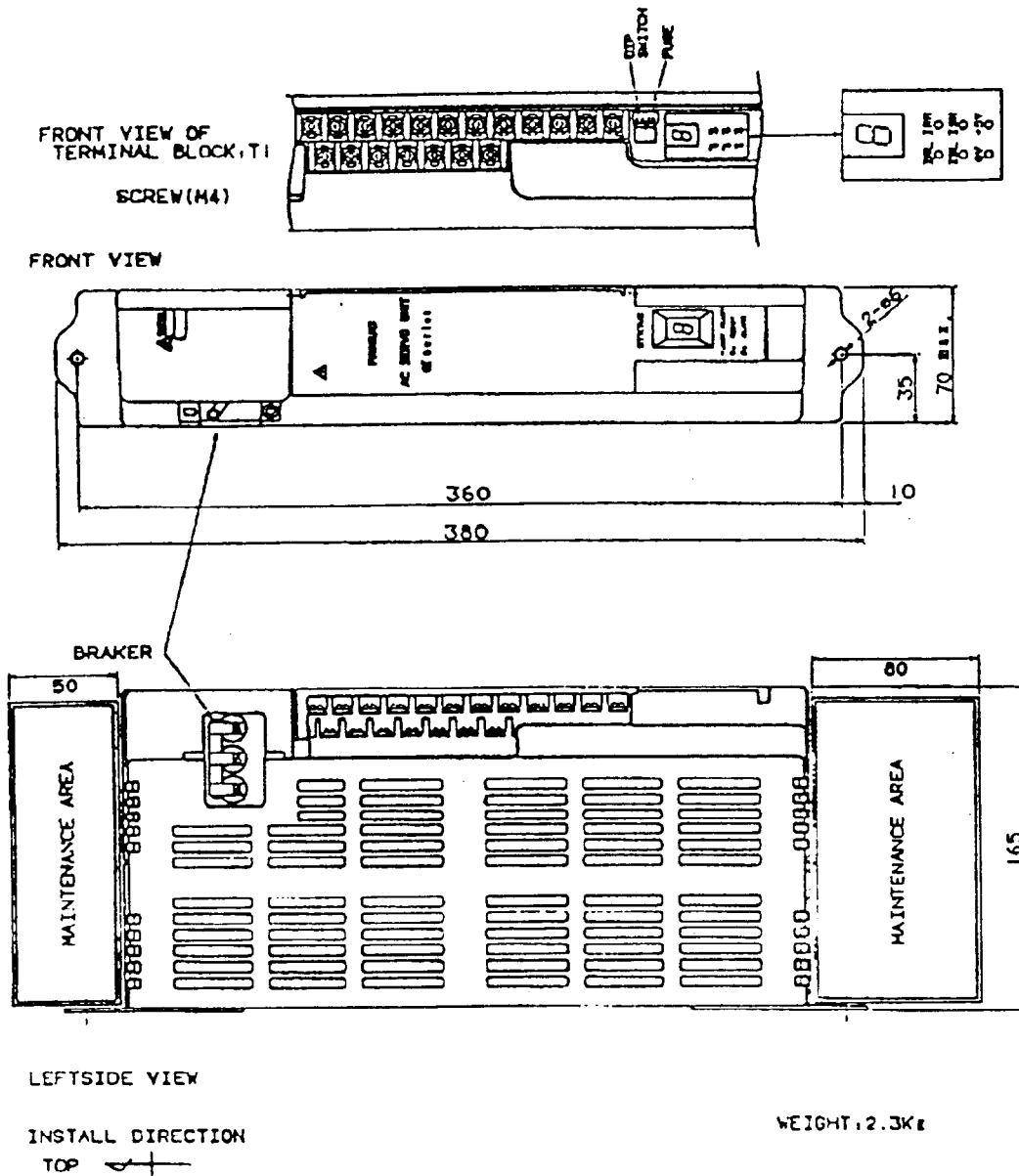

(b) SYUC1-4D.80

FRONT VIEW OF
TERMINAL BLOCK, TI

SCREW (M4)

FRONT VIEW

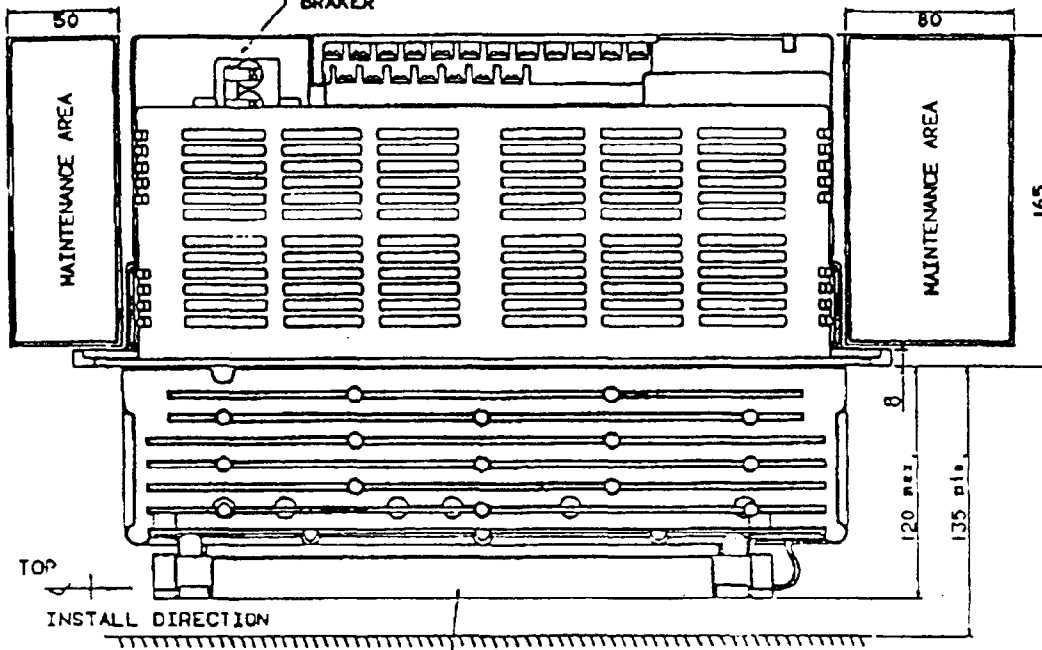
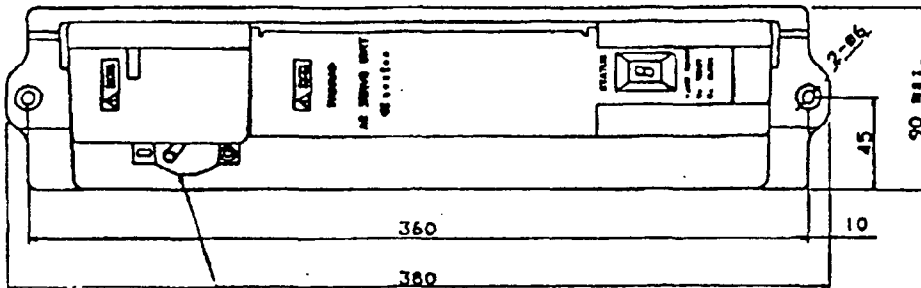
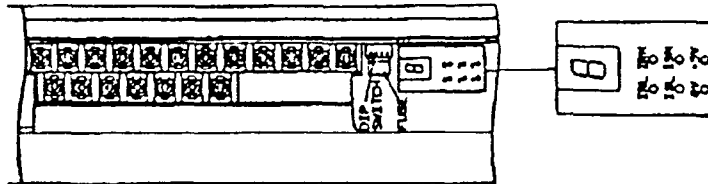

LEFTSIDE VIEW

REGENERATIVE DISCHARGE RESISTOR CAUTION: MOTI TAKH HANDS OFF.

WEIGHT: 4.9K±

CAUTION) PARTS INSTALLTION IS NOT PERMITTED HERE BECAUSE OF THE HEAT GENERATED BY THE DISCHARGE RESISTOR

(c) SYUC1-130

FRONT VIEW OF
TERMINAL BLOCK, T1
SCREW (M4)

FRONT VIEW

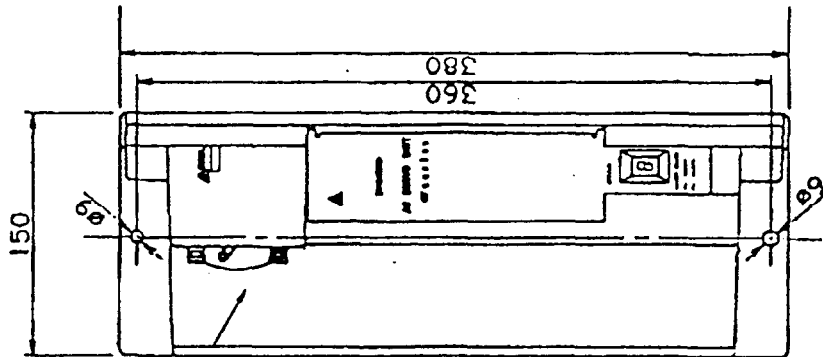
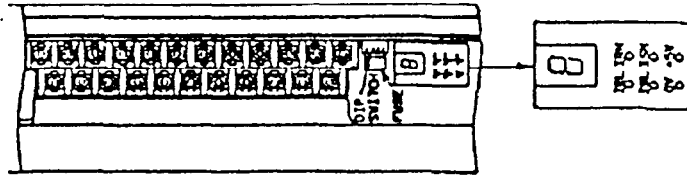

BRAKER

LEFT SIDE VIEW

INSTALL
DIRECTION

TOP

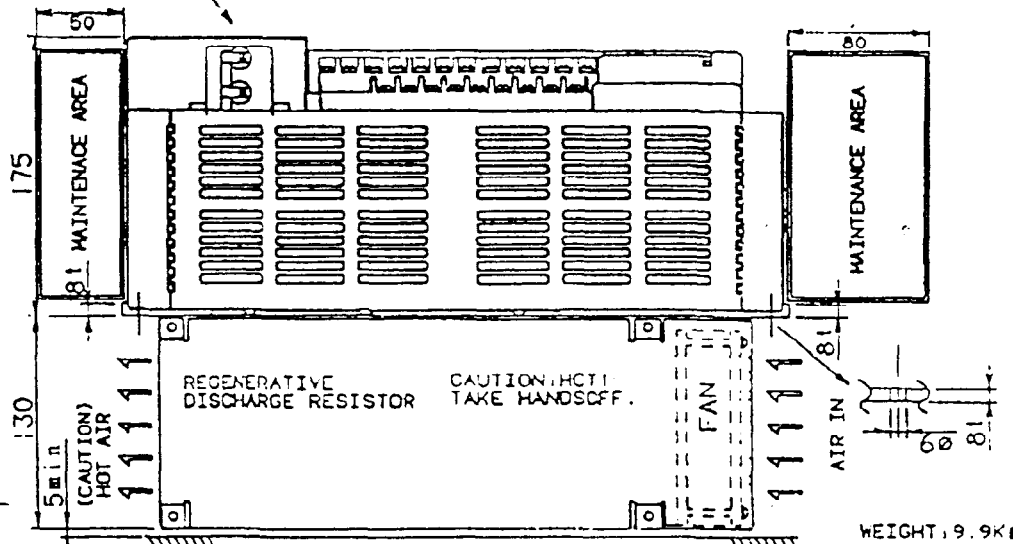

CAUTION) PARTS INSTALLATION IS NOT PERMITTED HERE
BECAUSE OF THE HEAT GENERATED BY THE DISCHARGE RESISTOR.

WEIGHT 9.9Kg

(d) SVUC2

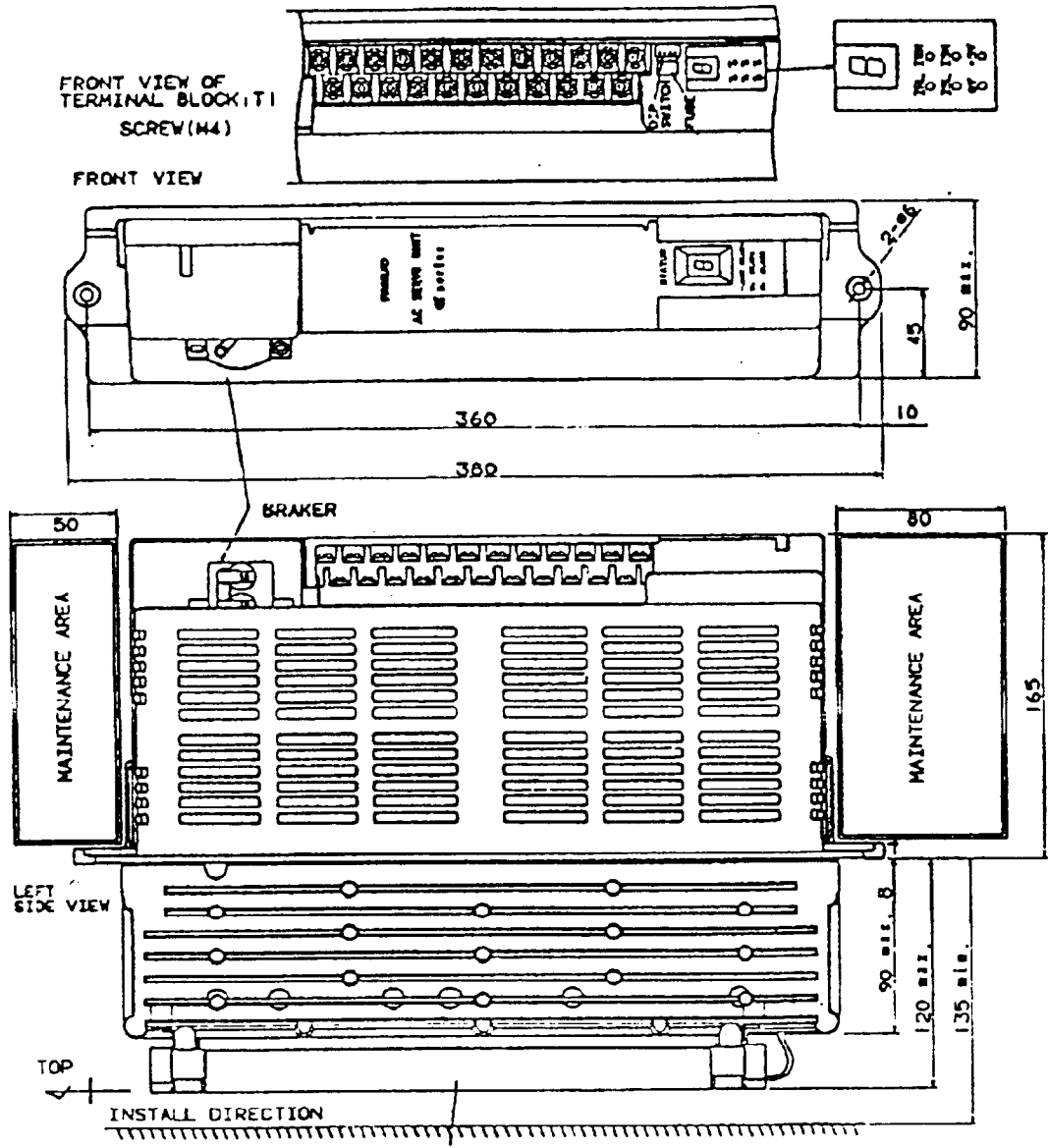

REGENERATIVE DISCHARGE UNIT

CAUTION: HOT! TAKE HANDSOFF.

WEIGHT: 5.8K1

CAUTION) PARTS INSTALLATION IS NOT PERMITTED BECAUSE OF THE HEAT GENERATED BY THE DISCHARGE RESISTOR

6. Maintenance level parts

Group	Name	Application	Designation	
Basic	Connector	JV(1/2)B, JS(1/2)B Between NC to SVUC (Plastic cover)	Soldering type	A06B-6073-K212
			Crimp type	A06B-6073-K213
	Connector	JV(1/2)B, JS(1/2)B Between NC to SVUC (Metal cover)	Soldering type	A06B-6066-K205
			Crimp type	A06B-6066-K206
	Connector	JF(1/2) For pulse coder		A06B-6073-K214
	Fuse	For control power supply For fanmotor (SVU ^F -130)	A06B-6089-K250	
Option	Fanmotor	For SVU ^F -130		
		Separate Regenerative Discharge Unit (A06B-6089-H711, H712, H713, H714)	A06B-6089-K203	
	Battery case	For absolute pulse coder (TYPE B I/F)	A06B-6050-K060	
	Battery	For absolute pulse coder (TYPE B I/F)	A06B-6050-K061	
	Battery cable	For absolute pulse coder (TYPE B I/F) (Length : 5m)	A02B-0120-K809	

- *No part of this manual may be reproduced in any form.*
- *All specifications and designs are subject to change without notice.*